



FULL PRODUCT LINE POCKET GUIDE

RESIDENTIAL & COMMERCIAL





The story is all in the details. Every water heater that carries the A. O. Smith name has a reputation to live up to, one that we've earned through 140 years of innovation. As an industry leader, we constantly look for new materials and develop new technologies that can improve energy efficiency. So, when you choose an A. O. Smith water heater, whether it's gas, electric or hybrid you can be confident that you are getting the best water heating solution regardless of the application—for today and for years to come. Innovation has a name... A. O. Smith.



All A. O. Smith residential water heaters meet the Federal Energy Efficiency Standards effective June 4, 2018, according to the National Appliance Energy Conservation Act (NAECA) of 1992, and meet the thermal efficiency and standby loss requirements of the U. S. Department of Energy and current edition of ASHRAE/IES 90.1. They also comply with the current edition of ICC Codes and the HUD Standards. Gas models meet American National Standards Institute Standards (ANSI Z21.10.1 - CSA 4.1) governing storage-type water heaters. Electric models are UL listed according to safety specifications outlined in Underwriters Laboratories, Inc. Standards for Safety (UL 174).

TABLE OF CONTENTS

Introduction	1
Table of Contents	2-4
Introducing the ProLine® Family.....	5
Contractor Rewards	6
ProLine® Gas Family Features.....	7
ProLine® Electric Family Features	8
ProLine® Tankless Family Features.....	9

RESIDENTIAL GAS

Vertex™ High Efficiency Power Vent	10-11
Vertex™ High Efficiency Power Direct Vent.....	12-13
Polaris® High Efficiency	14-15
ProLine® XE Non-Condensing Power Vent.....	16-17
ProLine® XE Non-Condensing Power Direct Vent	18-19
ProLine® XE High Efficiency Non-Condensing Flue Damper	20-21
ProLine® XE High Efficiency Non-Condensing Ultra-Low NOx Flue Damper.....	22-23
ProLine® XE High Efficiency Non-Condensing Ultra-Low NOx Power Vent.....	24-25
ProLine® Master Atmospheric Vent	26-29
ProLine® Master Ultra-Low NOx	28-29
ProLine® High Capacity Atmospheric Vent	30-31
ProLine® Direct Vent.....	32-33
ProLine® Atmospheric Vent	34-37
ProLine® Energy Saver Atmospheric Vent Mobile Home	38-39
ProLine® Energy Saver Direct Vent Mobile Home.....	40-41
ProLine® Ultra-Low NOx	42-43
ProLine® Ultra-Low NOx Direct Vent	44-46
ProLine® Ultra-Low NOx High Capacity.....	46-47

RESIDENTIAL HYBRID ELECTRIC

Voltex® Hybrid Electric Heat Pump - 10-Year Warranty	48-49
Voltex® Hybrid Electric Heat Pump - 6-Year Warranty	50-51

RESIDENTIAL ELECTRIC

ProLine® XE Electronic Display	52-53
ProLine® Electronic Thermostat	54-55
ProLine® Master	56-57
ProLine® Standard.....	58-59

TABLE OF CONTENTS

ProLine® 80 Gallon Electric	60-61
Mobile Home	62-63
ProLine® Specialty.....	64-65

RESIDENTIAL PUMP AND EXPANSION TANKS

Pump Tanks.....	66-67
Expansion Tanks	68-69

TANKLESS (RESIDENTIAL AND COMMERCIAL)

ProLine® XE X3P Series	70-71
ProLine® XE Combi Boiler	72-73
ProLine® XE Condensing with Recirculation Pump.....	74-75
ProLine® XE Condensing High Efficiency (140).....	76-77
ProLine® XE Condensing High Efficiency (240-540)	78-79
ProLine® XE Non-Condensing Concentric Vent.....	80-81
ProLine® XE Non-Condensing Ultra-Low NOx.....	82-83
Non-Condensing Heavy-Duty.....	84-85
Rack System.....	86-89
BACnet and Modbus Interface	90-91
Point-of-Use	92-93
Electric Tankless	94-95

COMMERCIAL GAS AND OIL FIRED

Cyclone® HE BTX-80	96-97
Cyclone® Xi BTX-100.....	98-99
Cyclone® Xi BTXL-100.....	100-101
Cyclone® MXi.....	102-105
Cyclone® LV.....	106-109
Polaris® High Efficiency.....	110-111
TX1 Integrated Tankless on Tank	112-113
Master-Fit® BTR.....	114-117
Master-Fit® Ultra-Low NOx	118-121
Conservationist® BT	122-123
Conservationist® Power Vent	124-125
Conservationist® Power Direct Vent	126-127
Conservationist® Ultra-Low NOx.....	128-129
Power Burner Light-Duty.....	130-131
Low NOx Power Burner.....	132-133
Conservationist® Duraclad Oil-Fired Tank-Type.....	134-135

TABLE OF CONTENTS

COMMERCIAL ELECTRIC

Light-Service	136-137
DEN/DEL Electric Dura-Power™	138-139
Gold Xi Series - DVE Electric.....	140-141
Gold Series - DRE Electric.....	142-143
Heavy-Duty Custom Xi	144-145
Heavy-Duty Premium Electric DVE/DHE Dura-Power™	146-151

COMMERCIAL HEAT PUMP

CHP-120 Fully Integrated Heat Pump.....	152-153
---	---------

CIRCULATING WATER HEATERS

XP High Efficiency Water Heater	154-155
XP ^{PLUS} High Efficiency Water Heater	156-157
Burkay® Genesis® Domestic Water Heater	158-159
Variable Fire™ High Efficiency Water Heater	160-161

HOT WATER SUPPLY BOILERS

Burkay® Energy Saver Copper Heat Exchanger	162-163
Burkay® HWH Gas Domestic Water Heaters & Boiler	164-165

HOT WATER GENERATOR

Steam or Boiler Hot Water HWG Generator Systems	166-167
---	---------

COMMERCIAL STORAGE TANKS

Standard Jacketed Storage Tank.....	168-169
Custom-Line Factory Jacketed & Insulated Storage Tank	170-173
Uninsulated Standard Stock Bare Storage Tank.....	174-177
Heavy-Duty Large Volume Storage Tanks Model HD Custom-Built	178-181

COMMERCIAL WATER HEATERS

AC-U-Temp Complete Hot Water Systems	182
Xpert Water Heater Selection Tool.....	183



Introducing the ProLine® Family of Commercial-Grade Residential Water Heaters



ProLine® XE
Vertex™

ProLine® Master

ProLine®

When it comes to building a tough commercial-grade water heater, the keys to success are outstanding components and superior manufacturing capabilities. We've combined these two important elements to create the ProLine® Family of commercial-grade residential water heaters. This wholesale-channel exclusive will give A. O. Smith's contractors the ultimate advantage.

WHY PROFESSIONALS CHOOSE A. O. SMITH



It's free and easy to participate. Enroll online at contractorrewards.com. Eligible products will have a yellow reward code label worth valuable points. Two ways to enter the codes:

1. Download the smartphone app and scan the code.
2. Enter the code at contractorrewards.com.
3. Redeem your points on thousands of reward items.



**CONTRACTOR
REWARDS.COM**
Your Business. Your Choices. Your Rewards.

WITH OVER 1,000,000 MERCHANDISE ITEMS, YOUR REWARD CHOICES ARE ENDLESS.

A. O. SMITH PROVIDES 6 KEY THINGS TO HELP GROW YOUR BUSINESS & BECOME MORE PROFITABLE

1. Contractor Locator

A new online locator that drives thousands of consumers from our website right to our loyal contractors. Your company listing is free and generated for you when you participate in our Contractor Rewards™ program.* Visit hotwater.com/contractorlocator for more information.

2. Contractor Rewards Program

Our program rewards our loyal contractors for buying our products. Buy more and get rewarded with prizes and higher status on our Contractor Locator.

3. Contractor Advertising Tools

Our Advertising Resource Center allows contractors to develop an easy, affordable and custom advertising campaign to promote their business. Go to www.hotwater.com/ads.

4. Breadth of Product Line

Residential or commercial, we have the most complete line from standard models to the most innovative high efficiency water heaters available.

5. Product Sales Tools

We provide contractors access to the sales tools needed to close more sales.

6. Brand Support

Marketing investment in our brand drives consumers to recognize our name, visit our website, locate local contractors and request products.

*To be listed on the Contractor Locator you must meet the minimum threshold of codes entered at contractorrewards.com

GAS WATER HEATERS

PREMIUM FEATURES. COMMERCIAL-GRADE COMPONENTS.

PREMIUM FEATURES:



OPERATING COST	\$\$\$	\$\$\$	\$
INSTALLATION SPACE REQUIRED	■ to ■■	■■■	■■■■
WARRANTY (YEARS)	6	8	6-10

Blue Diamond® Glass Coating	•	•	•
-----------------------------	---	---	---

DynaClean™ Automatic Sediment-Cleaning System	•	•	•
---	---	---	---

Self-Powered Electronic Gas Valve	•	•	•
-----------------------------------	---	---	---

Heat Trap Nipples	•	•	•
-------------------	---	---	---

Enhanced Flow Brass Drain Valve	•	•	•
---------------------------------	---	---	---

CoreGard™ Advanced Anode Rod Protection	•	•	•
---	---	---	---

ENERGY STAR® Qualified*			•
-------------------------	--	--	---

Electronic User Interface*			•
----------------------------	--	--	---

Over 90% Condensing Efficiency*			•
---------------------------------	--	--	---

Best In Class Material and Technology			•
---------------------------------------	--	--	---

Industry Leading Efficiency			•
-----------------------------	--	--	---

Multiple Venting Options			•
--------------------------	--	--	---

*Select Heat Pump Water Heater models only.

Hot Water Output, Cost of Operation, & Installation Space Required estimated based on typical applications/installations. For a more custom analysis of unique installations, visit hotwater.com and use our product selector tool.

ELECTRIC WATER HEATERS

PREMIUM FEATURES. COMMERCIAL-GRADE COMPONENTS.

PREMIUM FEATURES:



OPERATING COST	\$\$\$	\$\$\$	\$
INSTALLATION SPACE REQUIRED	■ to ■■	■■	■■■
WARRANTY (YEARS)	6	8	6-10

Blue Diamond® Glass Coating	●	●	●
-----------------------------	---	---	---

DynaClean™ Automatic Sediment-Cleaning System	●	●	●
---	---	---	---

Heat Trap Nipples	●	●	●
-------------------	---	---	---

Enhanced Flow Brass Drain Valve	●	●	●
---------------------------------	---	---	---

CoreGard™ Advanced Anode Rod Protection	●	●	●
---	---	---	---

ENERGY STAR® Qualified*			●
-------------------------	--	--	---

Electronic User Interface*			●
----------------------------	--	--	---

Industry Leading Efficiency*			●
------------------------------	--	--	---

*Select Heat Pump Water Heater models only.

Hot Water Output, Cost of Operation, & Installation Space Required estimated based on typical applications/installations.

For a more custom analysis of unique installations, visit hotwater.com and use our product selector tool.

TANKLESS WATER HEATERS

PREMIUM FEATURES. COMMERCIAL-GRADE COMPONENTS.

PREMIUM FEATURES:



OPERATING COST \$
 INSTALLATION SPACE REQUIRED ■
 WARRANTY (YEARS) 6-10

Model Family	Proline XE Non-Condensing ULN	Proline XE Non-Condensing Concentric Vent
Condensing		
Non-Condensing	•	•
Indoor Models	•	•
Outdoor Models	•	
BTUs	140k-199k	140k-199k
Recirculation Pump - DHW		
Recirculation Pump - Hydronic Heating		
Concentric Venting		•
Ultra-Low Nox	•	
ENERGY STAR® Qualified		

Model Family	Proline XE Condensing	Proline XE Condensing with Recirc Pump	Proline XE Combi Boiler
Condensing	•	•	•
Non-Condensing			
Indoor Models	•	•	•
Outdoor Models	•	•	
BTUs	120k-199k	199k	110k-199k
Recirculation Pump - DHW		•	
Recirculation Pump - Hydronic Heating			•
Concentric Venting			
Ultra-Low Nox	•	•	•
ENERGY STAR® Qualified	•	•	•

VERTEX™ HIGH EFFICIENCY POWER VENT



ENERGY STAR® QUALIFIED

Condensing Design

- Helical internal heat exchanger keeps hot combustion gases in the tank longer to extract more heat into the water
- High efficiency operation with 0.88 UEF (94% Thermal Efficiency) which saves money on operating costs compared to a standard efficiency gas water heater

Power Vent Design for Installation Versatility

- Power vent using PVC, CPVC, ABS or Polypropylene either thru-the-wall or thru-the-roof

Side-Mounted Taps for Recirculating Systems

- Hot and cold "side taps" allow Vertex Power Vent to be used for combination space/water heating applications

Intelli-Vent™* Gas Control with Silicon Nitride Hot Surface Ignitor

- Premium-grade hot surface ignitor eliminates standing pilot
- Electronic circuitry provides superior system diagnostics capabilities plus extremely precise temperature control

Blue Diamond® Glass Coating with Two Heavy Duty Anode Rods

- Provides superior corrosion resistance compared to the industry-standard glass lining

Green Choice® Gas Burner

- Patented eco-friendly burner design reduces NOx emissions by up to 33% and complies with Low-NOx emission requirements of less than 40 ng/J

Dynaclean™ Diffuser Dip Tube

Code Compliance

- Meets IBC and ICC National Codes
- Meets the thermal efficiency and standby loss requirements of the U.S. Department of Energy and current edition of ASHRAE/IES 90.1

6-Year Limited Tank and Parts Warranty

- For complete information, consult written warranty or go to hotwater.com

*Intelli-Vent™ is a registered trademark of Emerson Electric Company

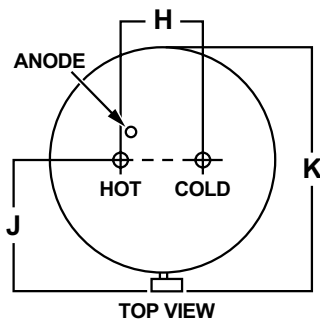

* INSTALL IN ACCORDANCE WITH LOCAL CODES

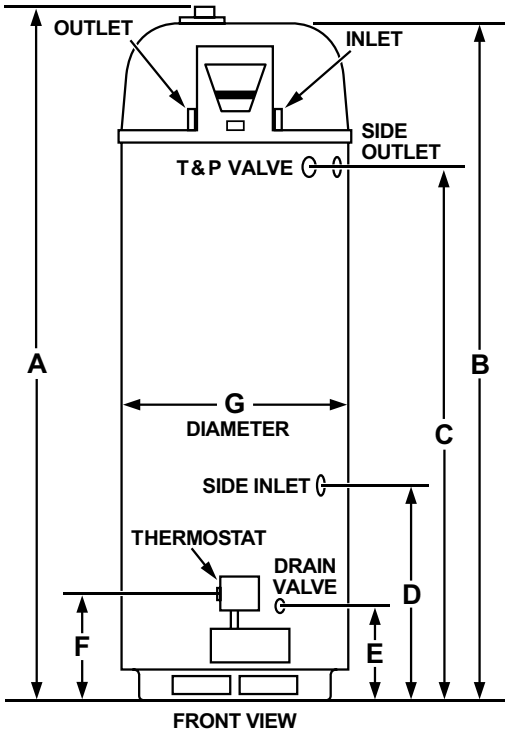

Model Number	Nominal Capacity	Rated Storage Volume	First Hour Rating (Gallons)	UEF	Thermal Efficiency	Recovery @ 90°F Rise Gallon Per Hour	BTU Input Per Hour
GPHE-50	50	48	124	0.88	94%	95	76,000

Model Number	Dimensions in Inches										Approx. Shipping Weight (lbs)
	A	B	C	D	E	F	G	H	J	K	
GPHE-50	71-1/8	68-5/8	52	21	9-1/8	12	22	8	15-3/4	27	225

Available in natural gas only.

Standard model certified for sea level to 5,300 ft. elevation. Order SMR K30 for elevations to 10,100 ft.

Optional Condensate Neutralizer Kit available (Part Number 100112380).

RESIDENTIAL GAS

VERTEX™ HIGH EFFICIENCY POWER DIRECT VENT



GDHE-75



ENERGY STAR® QUALIFIED

Condensing Design

- Helical internal heat exchanger keeps hot combustion gases in the tank longer to extract more heat into the water
- High efficiency operation with up to 0.88 UEF (96% Thermal Efficiency) which saves money on operating costs compared to a standard efficiency gas water heater

Advanced Electronic Control

- Optional Powered Anode available
- Exclusive A. O. Smith designed touch display control system
- Precise temperature control
- Built-in diagnostics and operational information

Power Direct Vent Design

- Power Direct vent using PVC, CPVC or Polypropylene either thru-the-wall or thru-the-roof
- Optional concentric vent and low profile termination kits are available

Ultra-Low NOx

- Complies with SCAQMD Rule 1146.2 and other air quality management districts with similar requirements for Ultra-Low NOx emissions requirements of 14 ng/J or 20 PPM

Side-Mounted Hot and Cold Recirculating Taps

- Hot and cold "side taps" allow Vertex Power Direct Vent to be used for combination space/water heating applications

Code Compliance

- Meets IBC and ICC National Codes
- Meets the thermal efficiency and standby loss requirements of the U. S. Department of Energy and current edition of ASHRAE/IES 90.1

6-Year Limited Tank and Parts Warranty

- For complete information, consult written warranty or go to hotwater.com

ROUGH IN DIMENSIONS: 50 GALLON UNIT

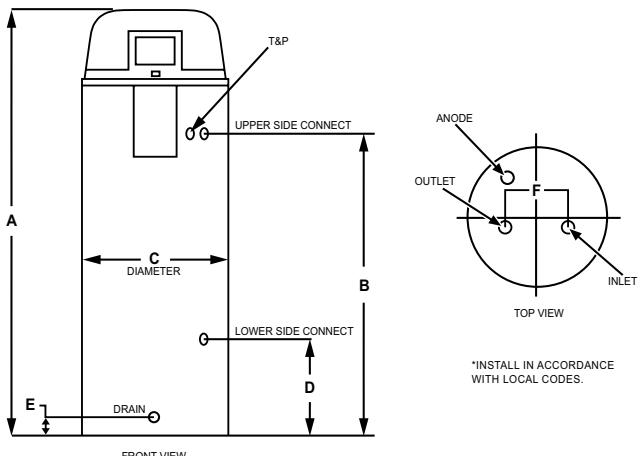

ROUGH IN DIMENSIONS: 75 GALLON UNIT

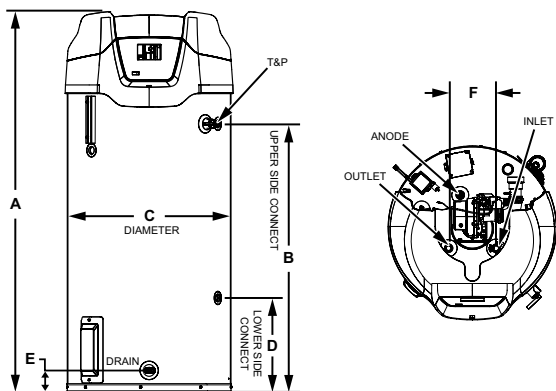

Model Number	Nominal Capacity	Rated Storage Volume	First Hour Rating (Gallons)	UEF	Thermal Efficiency	Recovery @ 90°F Rise Gallon Per Hour	BTU Input Per Hour
GDHE-50	50	49	100	0.88	96%	129	100,000
GDHE-75	75	74	130	0.86	96%	129	100,000

Model Number	Vent Size	Dimensions in Inches						Approx. Shipping Weight (lbs)
		A	B	C	D	E	F	
GDHE-50	2 or 3	66-3/4	49-1/4	22	15-3/4	3	8	255
GDHE-75	2 or 3	65-1/4	45-5/8	27-3/4	16	3-3/4	8	382

Available in Propane (LP) gas. Specify when ordering propane (LP) gas.
 Available with a Powered Anode. Specify when ordering.
 Models certified for sea level to 10,100 ft. elevation.
 Optional Condensate Neutralizer Kit available (part number 100112380).

RESIDENTIAL GAS

POLARIS® HIGH EFFICIENCY



ENERGY STAR® QUALIFIED

Stainless Steel Construction

- Tank and helical heat exchanger are constructed from 444 stainless steel for excellent corrosion resistance without the need for an anode

Condensing Design

- Helical internal heat exchanger keeps hot combustion gases in the tank longer to extract more heat into the water
- High efficiency operation with up to 0.90 UEF (96% Thermal Efficiency) which saves money on operating costs compared to a standard efficiency gas water heater

Power Direct Vent Design

- Direct vent using PVC, CPVC or ABS either thru-the-wall or thru-the-roof
- Optional concentric vent kit

Whisper Quiet Operation

- Ultra quiet blower and burner minimize noise

Advanced Electronic Control

- Exclusive A. O. Smith designed touch display control system
- Precise temperature control
- Built-in diagnostics and operational information

Ultra-Low NOx

- Complies with SCAQMD Rule 1146.2 and other air quality management districts with similar requirements for Ultra-Low NOx emissions requirements of 14 ng/J or 20 PPM

Code Compliance

- Meets IBC and ICC National Codes
- Meets the thermal efficiency and standby loss requirements of the U. S. Department of Energy and current edition of ASHRAE/IES 90.1

10-Year Limited Tank and 10-Year Parts Warranty

- For complete information, consult written warranty or go to hotwater.com

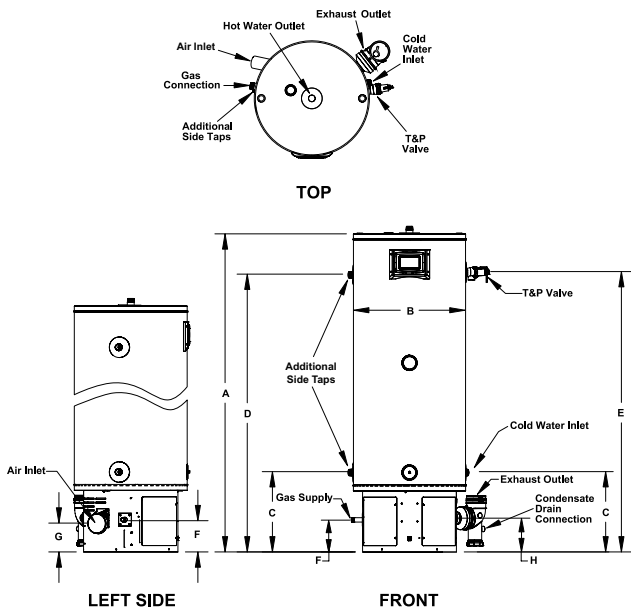

Model Number	Vent Connection	Nominal Capacity	Rated Storage Volume	First Hour Rating (Gallons)	UEF	Thermal Efficiency	Recovery @ 90° Rise Gallon Per Hour
GSP 100	2 or 3	34	33	179	0.90	96%	129
GSP 130	2 or 3	34	N/A	N/A	N/A	96%	165
GSP 150	2 or 3	34	N/A	N/A	N/A	94%	190
GTP 130	2 or 3	50	N/A	N/A	N/A	95%	165
GTP 150	2 or 3	50	N/A	N/A	N/A	95%	190
GTP 175	3	50	N/A	N/A	N/A	96%	222
GTP 199	3	50	N/A	N/A	N/A	96%	253

Model Number	BTU/h Input Gallon Per Hour	Dimensions in Inches		1" Water Connections		T&P	Gas Supply*	Approx. Shipping Weight (lbs)
		A	B	C	D	E	F	
GSP 100	100,000	48-1/2	22	15-3/4	40-1/2	41	6-3/8	150
GSP 130	130,000	48-1/2	22	15-3/4	40-1/2	41	6-3/8	150
GSP 150	150,000	48-1/2	22	15-3/4	40-1/2	41	6-3/8	150
GTP 130	130,000	62-3/8	22	15-3/4	54-1/2	55	6-3/8	176
GTP 150	150,000	63-3/4	22	15-3/4	55-3/4	56-1/4	6-3/8	180
GTP 175	175,000	63-3/4	22	15-3/4	55-3/4	56-1/4	6-3/8	180
GTP 199	199,000	63-3/4	22	15-3/4	55-3/4	56-1/4	6-3/8	180

Available in Propane (LP) gas. Specify when ordering Propane (LP) gas. Models certified for sea level to 7,700 ft. elevation.

PROLINE® XE NON-CONDENSING POWER VENT



Versatile Power Vent Design

- All models feature an exclusive 3-position rotatable blower outlet which adds flexibility
- Combined horizontal and vertical vent runs up to 180 equivalent feet with 4" diameter venting (ABS, PVC, CPVC and polypropylene)
- All models are equipped with a protected sensor that detects the presence of flammable vapors and automatically disables the burner to prevent ignition
- Air intake snorkel elevates the inlet location of combustion air to prevent flammable vapors from entering the sealed combustion chamber

Hot Surface Ignitor

- More robust and reliable than standing pilot, and reduces energy consumption

Built-in Heat Traps on the Water Inlet and Outlet Reduce the Amount of Heat Lost Through Piping

User-Friendly

- State-of-the-art electronic gas control provides more precise temperature control
- LED control light displays operation status and diagnostics information

Enhanced-Flow Brass Drain Valve Available in Natural Gas and Propane Code Compliance

- Meets UBC, CEC and HUD National Codes
- Meets the thermal efficiency and standby loss requirements of the U.S. Department of Energy and current edition of ASHRAE/IES 90.1
- Complies with the Federal Energy Conservation Standards effective April 16, 2015, in accordance with the Energy Policy and Conservation Act (EPCA) as amended

Design-Listed by CSA International

- Certified at 300 psi test pressure and 150 psi working pressure
- Listed according to ANSI Z21.10.1-CSA 4.1 standards governing storage tank-type water heaters

6-Year Limited Tank and Parts Warranty

- For complete information, consult written warranty or go to hotwater.com

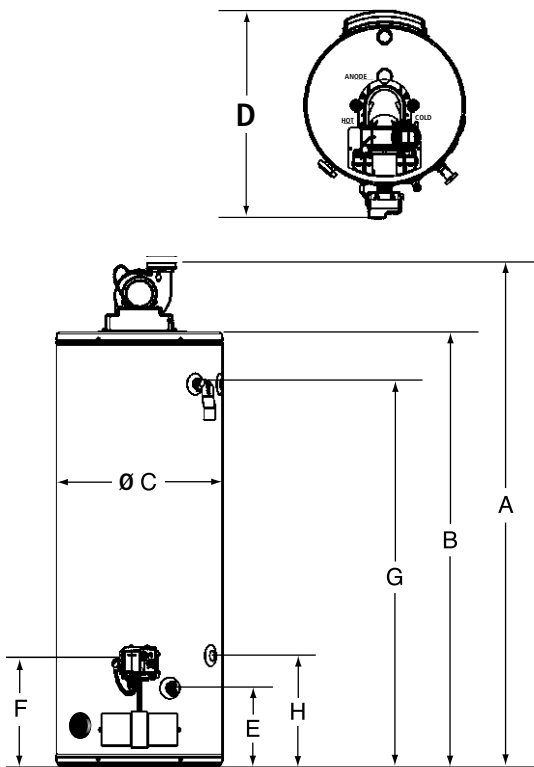

Model Number	Series	Nominal Capacity	Rated Storage Volume	UEF	First Hour Rating (Gallons)	Recovery @ 90°F Rise Gallon Per Hour	Input BTU/h
GPVL-40	200	40	38	0.67	72	45	40,000
GPVT-40	200	40	38	0.70	87	56	50,000
GPVL-50	200	50	49	0.72	79	45	40,000
GPVT-50	200	50	48	0.72	97	56	50,000
GPVX-50L	200	50	50	0.73	119	69	62,000
†GPVX-75L	310	75	72	0.69	116	80	76,000

Model Number	Dimensions in Inches								Approx. Shipping Weight (lbs)
	A	B	C	D	E	F	G	H	
GPVL-40	59	49-5/8	22	29-1/8	11	13-1/4	42-1/2	N/A	174
GPVT-40	68-1/2	59-1/4	20	27-1/8	11	13-1/4	53-1/8	15-1/4	176
GPVL-50	60-1/8	50-3/4	24	31-1/8	11	13-1/4	43-3/4	N/A	198
GPVT-50	68-1/8	58-3/4	22	29-1/8	11	13-1/4	51-3/4	15-1/4	192
GPVX-50L	61-1/8	52	24	31-1/8	11	13-1/4	44-1/2	15-1/4	212
†GPVX-75L	70-5/8	61-1/4	26	33-1/8	11	13-1/4	53	15-1/4	277

Available in propane (LP) gas. Specify when ordering propane (LP) gas.

Side connections are standard on GPVX models.

Side connections available on GPVT models. Add "L" to the model number (example: GPVT-40L).

All models are certified from sea level to 10,100 ft. elevation.

† GPVX-75L is not ENERGY STAR® Qualified.

PROLINE® XE NON-CONDENSING POWER DIRECT VENT



Power Direct Vent Design

- Combined horizontal and vertical vent runs up to 180 equivalent feet with 4" diameter venting (ABS, PVC, CPVC and polypropylene)
- Two-pipe sealed combustion system uses outside air, eliminating problems caused by insufficient indoor ventilation

Green Choice® Gas Burner

- Patented eco-friendly burner design reduces NOx emissions by up to 33% and complies with Low-NOx emission requirements of less than 40 ng/J

Hot Surface Ignitor

- More robust and reliable than standing pilot, and reduces energy consumption

DynaClean™ Diffuser Dip Tube

User-Friendly

- State-of-the-art electronic gas control provides more precise temperature control
- LED control light displays operation status and diagnostics information

Enhanced-Flow Brass Drain Valve

CSA Certified and ASME Rated T&P Relief Valve

Code Compliance

- Meets UBC, CEC and HUD National Codes
- Meets the thermal efficiency and standby loss requirements of the U.S. Department of Energy and current edition of ASHRAE/IES 90.1
- Complies with the Federal Energy Conservation Standards effective April 16, 2015, in accordance with the Energy Policy and Conservation Act (EPCA) as amended

Design-Listed by CSA International

- Certified at 300 psi test pressure and 150 psi working pressure
- Listed according to ANSI Z21.10.1-CSA 4.1 standards governing storage tank-type water heaters

6-Year Limited Tank and Parts Warranty

- For complete information, consult written warranty or go to hotwater.com

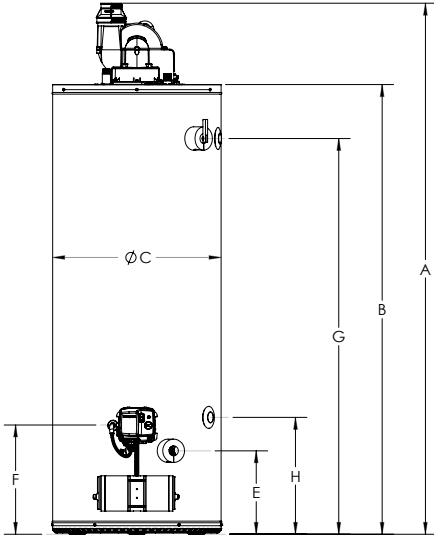
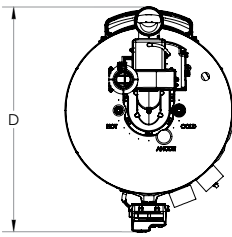

Model Number	Series	Nominal Capacity	Rated Storage Volume	UEF	First Hour Rating (Gallons)	Recovery @ 90°F Rise Gallon Per Hour	Input BTU/h
GPDL 40	200	40	38	0.68	74	45	40,000
GPDT 50	200	50	48	0.72	81	50	45,000
GPDX 50L	200	50	48	0.73	118	73	62,000**
† GPDX 75L	210	75	72	0.68	129	82	76,000

Model Number	Dimensions in Inches								Approx. Shipping Weight (lb)
	A	B	C	D	E	F	G	H	
GPDL 40	58-1/4	49-5/8	22	29-7/8	11	13-1/4	42-1/2	15-1/4	174
GPDT 50	67-1/2	58-3/4	22	29-7/8	11	13-1/4	51-3/4	15-1/4	192
GPDX 50L	69	60-1/4	22	29-7/8	11	13-1/4	52-3/4	15-1/4	200
† GPDX 75L	70-5/8	61-1/2	26	33-7/8	11	13-1/4	53	15-1/4	277

**Propane model has input of 58,000 BTU/hr.

Available in propane (LP) gas. Specify when ordering propane (LP) gas.

Side connections are standard on GPDX-50L and GPDX-75L.

Side connections available on GPDL-40 and GPDT-50. Add "L" to the model number (example: GDPT-50L).

All models are certified from sea level to 10,100 ft. elevation.

† GPVX-75 is not ENERGY STAR® Qualified.

RESIDENTIAL GAS

PROLINE® XE HIGH EFFICIENCY NON-CONDENSING FLUE DAMPER



Automatic Flue Damper

- Increases efficiency as it automatically opens and closes to reduce heat loss in the standby mode

Electronic Gas Control

Diagnostics

Electronic Ignition

Dynaclean™ Diffuser Dip Tube

Green Choice® Gas Burner

- Patented eco-friendly burner design reduces NOx emissions by up to 33% and complies with Low-NOx emission requirements of less than 40 ng/J

CoreGard™ Anode Rod

Enhanced-Flow Brass Drain Valve

Blue Diamond® Glass Coating

CSA Certified And ASME RATED T&P Relief Valve

Code Compliance

- Meets UBC, CEC and HUD National Codes.
- Meets the thermal efficiency and standby loss requirements of the U.S. Department of Energy and current edition of ASHRAE/IES 90.1
- Complies with the Federal Energy Conservation Standards effective April 16, 2015, in accordance with the Energy Policy and Conservation Act, (EPCA), as amended

Design-Certified by CSA International

- Certified at 300 psi test pressure and 150 psi working pressure
- Listed according to ANSI Z21.10.1 - CSA 4.1 standards governing storage tank-type water heaters

6-Year Limited Tank and Parts Warranty

- For complete information, consult written warranty or go to hotwater.com

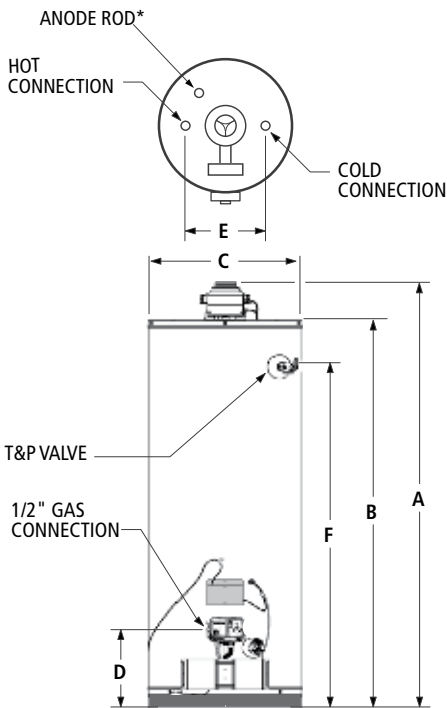

* Location for optional top-mounted T&P Valve if ordered from factory.

Maximum Hydrostatic Working Pressure: 150 PSI.

Model Number	Nominal Capacity	Rated Storage Volume	First Hour Rating (Gallons)	UEF	BTU Input Gallon Per Hour Natural*	Recovery @ 90°F Rise Gallon Per Hour	Approx. Shipping Weight (lbs)
Tall Models							
GCF-40	40	38	70	0.64	40,000	42	152
GCF-50	50	48	84	0.69	40,000	42	167
Short Models							
GCFL-40	40	38	65	0.66	40,000	42	149
*GCFL-50	50	49	78	0.69	40,000	42	175

Model Number	Dimensions in Inches							Draft Hood Outlet
	Foam Thickness	A	B	C	D	E	F	
Tall Models								
GCF-40	2	64-1/4	58-1/4	20	13	8	51-3/4	3 or 4
GCF-50	2	63-1/2	57-1/4	22	13	8	50-1/4	3 or 4
Short Models								
GCFL-40	2	54	47-3/4	22	13	8	41	3 or 4
*GCFL-50	2	55-3/4	49-1/2	24	13-1/4	8	42-1/2	3 or 4

Requires 120 VAC power supply.

Water connection is 3/4" on all models.

All models are certified from sea level to 10,100 ft. elevation.

*GCFL-50 available in natural gas only. All other models available in propane (LP) gas.

RESIDENTIAL GAS

PROLINE® XE HIGH EFFICIENCY NON-CONDENSING ULTRA-LOW NO_x FLUE DAMPER



ENERGY STAR® Efficiency

- Eco-friendly non-CFC foam insulation and an automatic flue damper increase efficiency to provide maximum household annual operating cost savings

Green Choice® Gas Burner

- Enhanced Ultra-Low NO_x burner complies with SCAQMD Rule 1121 and other air quality management districts with similar requirements for NO_x emissions of less than 10ng/J

Electronic Gas Control

DynaClean™ Diffuser Dip Tube

CoreGard™ Anode Rod

Blue Diamond® Glass Coating

Enhanced-Flow Brass Drain Valve

Requires 120V Power; 19.5 Ft Cord Included

Code Compliance

- Meets UBC, CEC, and HUD (excluding mobile homes) National Codes
- Meets the thermal efficiency and standby loss requirements of the U.S. Department of Energy and current edition of ASHRAE/IES 90.1
- Complies with the Federal Energy Conservation Standards effective April 16, 2015, in accordance with the Energy Policy and Conservation Act (EPCA), as amended

CSA and Design-Certified by CSA International

- Certified at 300 psi test pressure and 150 psi working pressure
- Listed according to ANSI Z21.10.1 – CSA 4.1 standards governing storage tank-type water heaters

6-Year Limited Tank and Parts Warranty

- For complete information, consult written warranty or go to hotwater.com

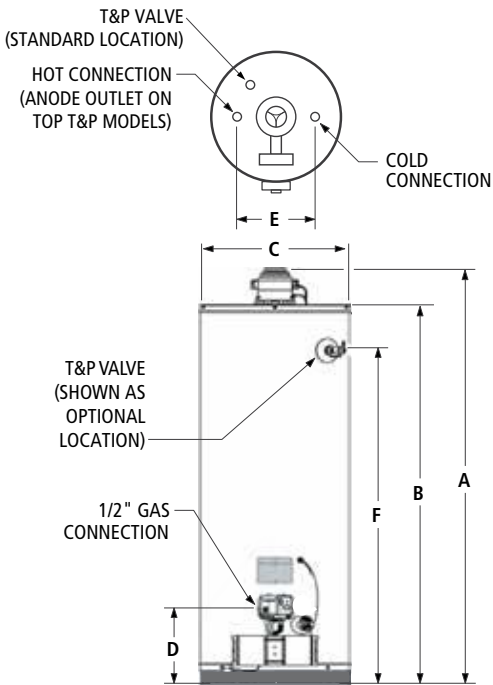

Maximum Hydrostatic Working Pressure: 150 PSI.

Model Number	Nominal Capacity	Rated Storage Volume	UEF	First Hour Rating (Gallons)	Recovery @ 90F Rise (Gallon/Hour)	BTU Input Natural Gas	Approx. Shipping Weight
GUF-40	40	38	0.65	68	42	40,000	152
GUF-50	50	48	0.70	83	42	40,000	167

Model Number	Dimensions in Inches						Draft Hood Outlet
	A	B	C	D	E	F	
GUF-40	64-1/4	58-1/4	20	13	8	51-3/4	3 or 4
GUF-50	63-1/2	57-1/4	22	13	8	50-1/4	3 or 4

Requires 120VAC power supply located within 19ft of the heater.

Water connection is 3/4" on all models.

Standard top T&P, specify when ordering side T&P.

All models are certified from sea level to 7,800ft elevation.

RESIDENTIAL GAS

PROLINE® XE HIGH EFFICIENCY NON-CONDENSING ULTRA-LOW NO_x POWER VENT



Power Venting Made Simple

- Thru-the-wall or thru-the-roof power venting using either 2" or 3" PVC, ABS or CPVC vent pipe

Intelli-Vent™ Gas Control

- Advanced electronics for more precise control of water temperature and easy to understand system diagnostics

Combination Thermostat/ECO

- Utilizes an intermittent ignition gas valve (no standing pilot) with thermistor temperature sensor and built-in high temperature cut off

Quiet and Efficient Blower

- Factory-installed 6-foot power cord with standard 3-prong male connector provided
- Electrical requirements; 110/120 VAC power source less than 5 amp draw

Dynaclean™ Diffuser Dip Tube

- Reduces lime and sediment buildup and maximizes hot water output
- Made from long-lasting PEX cross-linked polymer

Coregard™ Anode Rod

Green Choice® Gas Burner

- Complies with SCAQMD Rule 1121 and other air quality management districts with similar requirements for NO_x emissions of less than 10 ng/J

Enhanced-Flow Brass Drain Valve

Code Compliance

- Meets UBC, CEC and HUD National Codes
- Meets the thermal efficiency and standby loss requirements of the U. S. Department of Energy and current edition of ASHRAE/IES 90.1
- Complies with the Federal Energy Conservation Standards effective April 16, 2015, in accordance with the Energy Policy and Conservation Act, (EPCA), as amended

Design-Certified by CSA-International

- Certified at 300 psi test pressure and 150 psi working pressure
- Listed according to ANSI Z21.10.1-CSA 4.1 standards governing storage tank-type gas water heaters

6-Year Limited Tank and Parts Warranty

- For complete information, consult written warranty or go to hotwater.com

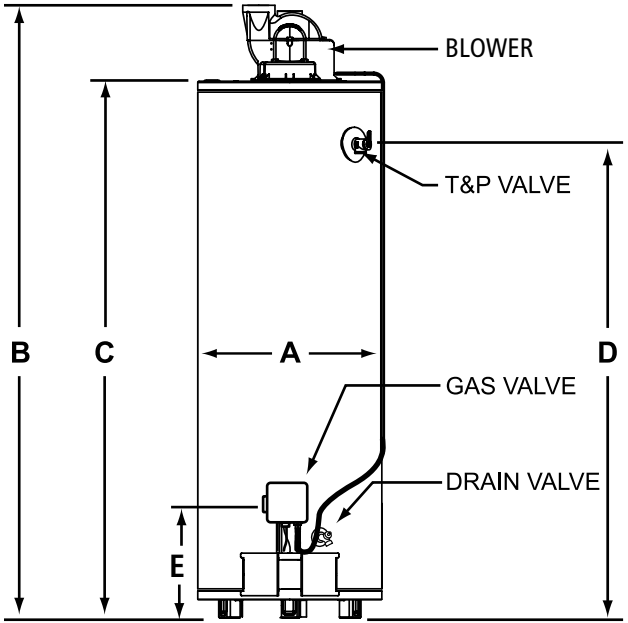
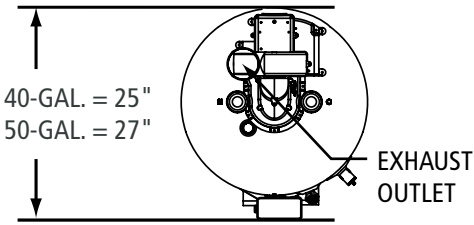

Model Number	Nominal Capacity	Rated Storage Volume	First Hour Rating (Gallons)	UEF	Recovery @ 90°F Rise Gallon Per Hour	BTU Input Gallon Per Hour
GPNH-40	40	38	76	0.70	42.6	42,000
GPNH-50	50	48	71	0.65	42.6	42,000

Model Number	Dimensions in Inches					Approx. Shipping Weight (lbs)
	A	B	C	D	E	
GPNH-40	20	66-7/8	58-5/8	51-1/2	12-1/4	170
GPNH-50	22	65-7/8	57-7/16	51	12-1/4	207

No option available for top T&P valve.

RESIDENTIAL GAS

PROLINE® MASTER ATMOSPHERIC VENT



Intelligent Control Logic*

- The internal microprocessor provides enhanced operating parameters and tighter differentials for precise sensing and faster heating response to optimize performance
- Uses a thermopile to generate the power needed to operate the electronic gas control without requiring an external power source
- The electronic gas control incorporates an LED status indicator that monitors system operation and service diagnostics

DynaClean™ Diffuser Dip Tube

CoreGard™ Anode Rod

- ProLine® Master products have increased anode protection with either longer or multiple anodes, depending on model

Push-Button Piezo Ignitor

Enhanced-Flow Brass Drain Valve

Heat Trap Nipple

Blue Diamond® Glass Coating

- Blue Diamond® Glass Coating blend is formulated in the same lab that creates the protection for our industry-leading commercial product line

Code Compliance

- Meets UBC, CEC and HUD National Codes.
- Meets the thermal efficiency and standby loss requirements of the U.S. Department of Energy and current edition of ASHRAE/IES 90.1
- Complies with the Federal Energy Conservation Standards effective April 16, 2015, in accordance with the Energy Policy and Conservation Act (EPCA), as amended

Design-Certified By CSA International

- Certified at 300 psi test pressure and 150 psi working pressure
- Listed according to ANSI Z21.10.1-CSA 4.1 standards governing storage tank-type gas water heaters

8-Year Limited Tank and Parts Warranty

- For complete information, consult written warranty or go to hotwater.com

*Not available on 60,000 BTU input models (HWRT-50 and HWRX-55)

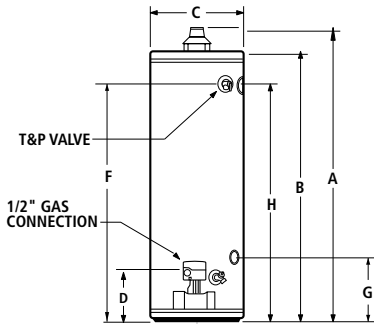
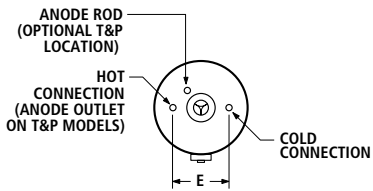

Maximum Hydrostatic Working Pressure: 150 PSI

Model Number	Nominal Capacity	Rated Storage Volume	First Hour Rating Gallon	UEF	BTU Input Natural Gas	BTU Input Propane Gas	Recovery 90°F Rise Gallon Per Hour
Tall Models							
HWR-40	40	38	80	0.66	40,000	36,000	42
HWG-50	50	48	81	0.62	40,000	37,000	41
HWR-50	50	48	84	0.62	40,000	37,000	43
HWRT-50	50	48	89	0.61	50,000	45,000	54
HWRX-55*	55	55	83	0.62	60,000	54,000	65
Short Models							
HWRL-40	40	38	67	0.59	40,000	36,000	41
HWRL-50	50	50	81	0.62	40,000	40,000	43

Model Number	Dimensions in Inches				
	A	B	C	D	E
Tall Models					
HWR-40	61-3/4	58-1/4	20	12-1/4	8
HWG-50	60-3/4	57-1/4	21	12-1/4	8
HWR-50	60-3/4	57-1/4	22	12-1/4	8
HWRT-50	60-3/4	57-1/4	22	12-1/4	8
HWRX-55*	59-3/4	55-1/4	24	13-1/2	8
Short Models					
HWRL-40	51-1/2	48	22	12	8
HWRL-50	53-1/4	49-3/4	24	12	8

Model Number	Dimensions in Inches				Approx. Shipping Weight (lbs)
	F	*G	*H	Draft Hood Outlet	
Tall Models					
HWR-40	52	N/A	N/A	3 or 4	138
HWG-50	50 1/2	N/A	N/A	3 or 4	148
HWR-50	50-1/2	N/A	N/A	3 or 4	165
HWRT-50	50-1/2	14-1/4	50-1/2	4	165
HWRX-55*	48	14-1/4	48	4	185
Short Models					
HWRL-40	41-1/4	N/A	N/A	3 or 4	135
HWRL-50	41-3/8	N/A	N/A	3 or 4	177

*For optional side-mounted recirculating taps, add "L" to the suffix in the model number. Water connection is 3/4" on all models.

All models approved for installation from sea level to 10,100 ft. elevation. Specify when ordering propane (LP) gas.

RESIDENTIAL GAS

PROLINE® MASTER ULTRA-LOW NOx



The Electronic Gas Control Incorporates an LED Status Indicator that Monitors System Operation and Service Diagnostics

High Uniform Energy Factors (UEFs)

- Eco-Friendly non-CFC foam insulation, external heat traps and specially designed combustion chamber combine to produce a high UEF for maximum savings on operating costs

Green Choice® Gas Burner

- Enhanced Ultra-Low NOx burner complies with SCAQMD Rule 1121 and other air quality management districts with similar requirements for NOx emissions of less than 10 ng/l

DynaClean™ Diffuser Dip Tube

CoreGard™ Anode Rod

- ProLine® Master products have increased anode protection with either longer or multiple anodes, depending on model

Push-Button Piezo Ignitor

Heat Trap Nipples

Blue Diamond® Glass Coating

- Blue Diamond® Glass Coating blend is formulated in the same lab that creates the protection for our industry-leading commercial product line

Enhanced-Flow Brass Drain Valve

Code Compliance

- Meets UBC, CEC and HUD National Codes
- Meets the thermal efficiency and standby loss requirements of the U.S. Department of Energy and current edition of ASHRAE/IES 90.1
- Complies with the Federal Energy Conservation Standards effective April 16, 2015, in accordance with the Energy Policy and Conservation Act (EPCA), as amended

CSA Certified by CSA International

Design-Certified by CSA International

- Certified at 300 psi test pressure and 150 psi working pressure. Listed according to ANSI Z21.10.1-CSA 4.1 standards governing storage tank-type gas water heaters

8-Year Limited Tank and Parts Warranty

- For complete information, consult written warranty or go to hotwater.com

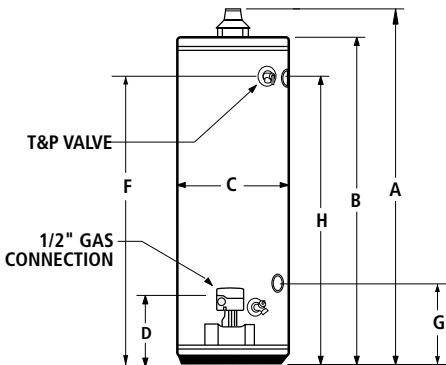
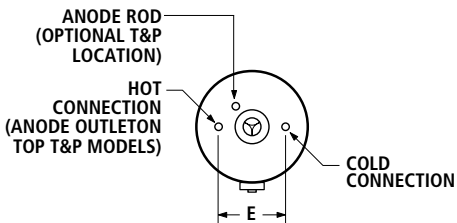

Maximum Hydrostatic Working Pressure: 150 PSI

Model Number	Nominal Capacity	Rated Storage Volume	First Hour Rating Gallon	UEF	BTU Input Natural Gas	Recovery @ 90°F Rise Gallon Per Hour	Approx. Shipping Weight (lbs)
Tall Models							
HUC-40	40	38	72	0.55	40,000	41	125
HUR-40	40	38	81	0.64	40,000	41	125
HUC-50	50	48	84	0.61	40,000	42	148
HUR-50	50	48	84	0.64	40,000	42	148
HURT-50L*	50	48	91	0.60	50,000	51	177
Short Models							
HURL-40	40	38	72	0.57	40,000	41	138

Model Number	Dimensions in Inches								Draft Hood Outlet
	A	B	C	D	E	F	G*	H*	
Tall Models									
HUC-40	62	58-1/4	18	12	8	52	N/A	N/A	3 or 4
HUR-40	62	58-1/4	20	12	8	52	N/A	N/A	3 or 4
HUC-50	60-3/4	57-1/4	20	12	8	50-1/2	N/A	N/A	3 or 4
HUR-50	60-3/4	57-1/4	22	12	8	50-1/2	N/A	N/A	3 or 4
HURT-50L*	61	57-1/2	22	11-1/4	8	50-1/2	12-1/4	50-1/2	4
Short Models									
HURL-40	51-1/2	47-3/4	22	12	8	41-1/4	N/A	N/A	3 or 4

All models may be ordered from the factory with top T&P.

*Side loop connections are standard on model (HURT-50L).

All models approved for 10,1000 ft. elevation.

RESIDENTIAL GAS

PROLINE® HIGH CAPACITY ATMOSPHERIC VENT



Highest Recoveries

- Capacity/input combinations up to 98 gallons/75,100 BTU's to produce recoveries up to 81 gallons per hour

The Electronic Gas Control Incorporates an LED Status Indicator that Monitors System Operation and Service Diagnostics

Green Choice® Gas Burner

- Patented eco-friendly burner design reduces NOx emissions up to 33% and complies with Low-NOx emission requirements of 40 ng/J

DynaClean™ Diffuser Dip Tube

CoreGard™ Anode Rod

Push-Button Piezo Ignitor

Blue Diamond® Glass Coating

Enhanced-Flow Brass Drain Valve

Code Compliance

- Meets UBC, CEC and ICC National Codes
- Meets the thermal efficiency and standby loss requirements of the U.S. Department of Energy and current edition of ASHRAE/IES 90.1

CSA Certified and ASME Rated T&P Relief Valve

Maximum Hydrostatic Working Pressure: 150 psi

Design-Certified By CSA International

- Certified at 300 psi test pressure and 150 psi working pressure
- Listed according to ANSI Z21.10.1-CSA 4.1 standards governing storage tank-type gas water heaters

6-Year Limited Tank and Parts Warranty

- For complete information, consult written warranty or go to hotwater.com



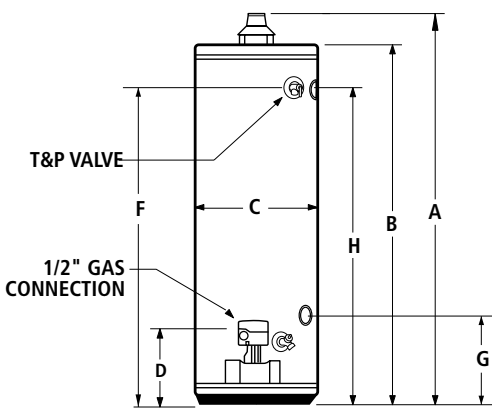
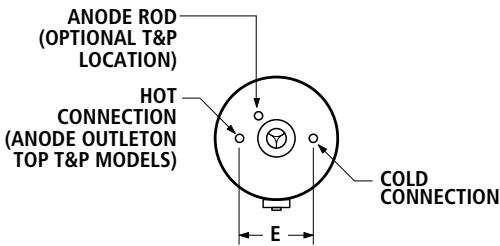

Maximum Hydrostatic Working Pressure: 150 PSI

Model Number	Nominal Capacity	Rated Storage Volume	UEF	First Hour Rating (Gallons)	Recovery @ 90°F Rise Gallon Per Hour	BTU Input Natural Gas
FCG-75	74	71	0.60	125	81	75,100
FCG-100	98	95	0.58	170	81	75,100

Model Number	Dimensions in Inches					Approx. Shipping Weight (lbs)
	A	B	C	D	E	
FCG-75	61	58-1/2	26-1/2	15-3/16	16	270
FCG-100	68-1/2	66-1/2	27-3/4	15-3/16	16	340

Model Number	Dimensions in Inches			
	F	G	H	Draft Hood Outlet
FCG-75	50-1/4	15-1/2	50-1/4	4
FCG-100	57-3/8	N/A	N/A	4

Water connections are 1" male NPT on FCG-75 and 1-1/4" on FCG-100.
 For 10-year tank and 10-year parts limited warranty, change "F" to "P" in model number (example: PCG-75).
 For optional side-mounted recirculating taps, add "L" to the suffix of the model number (example: FCG-75L).
 Specify when ordering propane (LP) gas.
 All models are certified from sea level to 7,700 ft. elevation.

RESIDENTIAL GAS

PROLINE® DIRECT VENT



Direct Vent Design

- One-pipe, dual-channel closed system draws all make-up air from outside the home, eliminating problems caused by insufficient indoor ventilation and is FVIR compliant
- Horizontal air intake and venting on all models up to 80 inches from outside wall with no electrical power needed

Intelligent Control Logic

Green Choice® Gas Burner

- Patented eco-friendly burner design reduces NOx emissions by up to 33% and complies with Low-NOx emission requirements of less than 40 ng/J

DynaClean™ Diffuser Dip Tube

CoreGard™ Andode Rod

Push Button Piezo Ignitor

Heat Trap Nipples

Code Compliance

- Meets UBC, CEC and HUD National Codes
- Meets the thermal efficiency and standby loss requirements of the U.S. Department of Energy and current edition of ASHRAE/IES 90.1
- Complies with the Federal Energy Conservation Standards effective April 16, 2015, in accordance with the Energy Policy and Conservation Act (EPCA), as amended

Design-Certified by CSA International

- Certified at 300 psi test pressure and 150 psi working pressure. Listed according to ANSI Z21.10.1-CSA 4.1 standards governing storage tank-type gas water heaters

6-Year Limited Tank and Parts Warranty

- For complete information, consult written warranty or go to hotwater.com



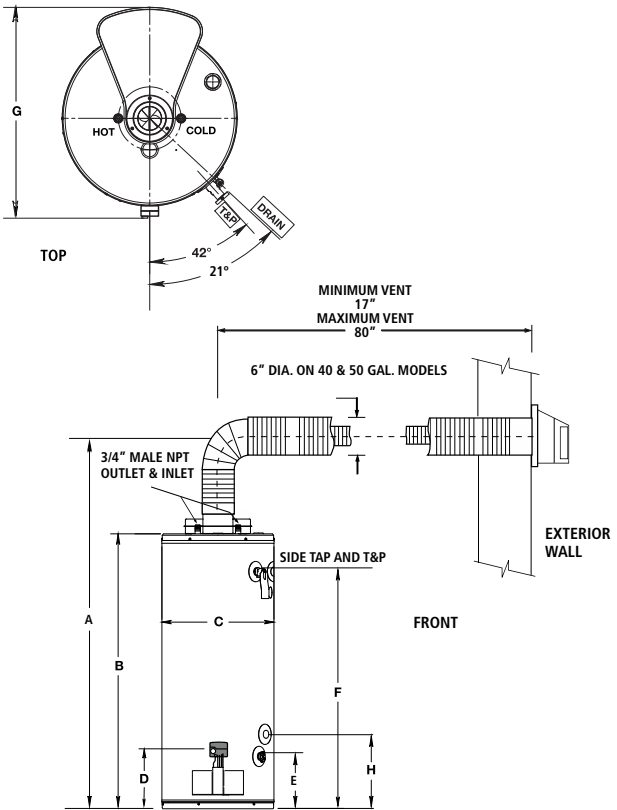

Model Number	Nominal Capacity	Rated Storage Volume	First Hour Rating (Gallons)	UEF	Input BTU Per Hour	Recovery 90°F Rise Gallon Per Hour	Vent Outlet
GDV-40	40	39	64	0.60	38,000	41	Co-Axial
GDV-50	50	48	77	0.66	40,000	43	Co-Axial
GDVT-50	50	48	83	0.65	47,000	51	Co-Axial

Model Number	Dimensions in Inches								Approx. Shipping Weight (lbs)
	A	B	C	D	E	F	*G	H	
GDV-40	64	49-3/4	22	13-1/4	15-1/4	42-1/2	29	15-1/4	178
GDV-50	73	59	22	13-1/4	15-1/4	51-3/4	29	15-1/4	200
GDVT-50	74	60	22	13-1/4	15-1/4	52-3/4	29	15-1/4	215

Dual-channel system has 3" vent pipe inside 6" air intake pipe, for the 40 and 50-gallon models.

All models have 2" foam cavity.

Water connection is 3/4" male on all models.

40 and 50 gallon models are 8" on center.

*Allow 29-1/2" for front to back dimension for gas control and air intake pipe at the rear of the heater.

All models are available in propane (LP) gas (series 301).

All models are certified from sea level to 7,700 ft. elevation.

All models available with side connections. Add "L" to the model number, example GDV-40L.

PROLINE® ATMOSPHERIC VENT



Intelligent Control Logic*

- The internal microprocessor provides enhanced operating parameters and tighter differentials for precise sensing and faster heating response to optimize performance
- Uses a thermopile to generate the power needed to operate the electronic gas control without requiring an external power source
- The electronic gas control incorporates an LED status indicator that monitors system operation and service diagnostics

*Not available on 60,000 BTU input models (GCRX-50 and GCRX-55)

DynaClean™ Diffuser Dip Tube

CoreGard™ Anode Rod

Push-Button Piezo Ignitor

Enhanced-Flow Brass Drain Valve

Heat Trap Nipple

Blue Diamond® Glass Coating

Code Compliance

- Meets UBC, CEC and HUD National Codes
- Meets the thermal efficiency and standby loss requirements of the U.S. Department of Energy and current edition of ASHRAE/IES 90.1
- Complies with the Federal Energy Conservation Standards effective April 16, 2015, in accordance with the Energy Policy and Conservation Act (EPCA), as amended

Design-Certified By CSA International

- Certified at 300 psi test pressure and 150 psi working pressure
- Listed according to ANSI Z21.10.1-CSA 4.1 standards governing storage tank-type gas water heaters

6-Year Limited Tank and Parts Warranty

- For complete information, consult written warranty or go to hotwater.com

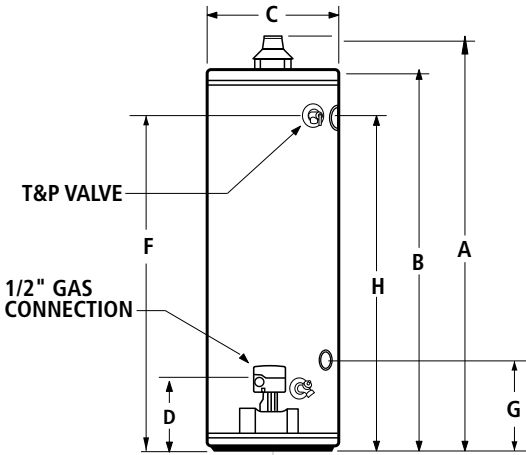
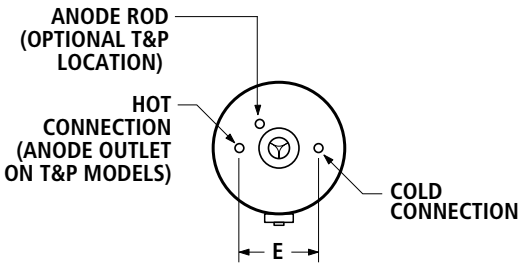

Maximum Hydrostatic Working Pressure: 150 PSI

Line drawings and dimensions on the following page.

RESIDENTIAL GAS

PROLINE®

ATMOSPHERIC VENT (CONTINUED)

Model Number	Nominal Gallon Capacity	Rated Storage Volume	First Hour Rating (Gallons)	UEF	BTU Input Natural Gas	BTU Input Propane Gas	Recovery 90°F Rise Gallon Per Hour
Tall Models							
†GCB-30R	30	29	62	0.60	32,000	29,000	32
GCR-30R	30	29	62	0.60	32,000	29,000	31
‡GCRH-40	40	38	65	0.61	35,500	N/A	38
†GCB-40	40	38	78	0.65	40,000	36,000	42
GCR-40*	40	38	80	0.66	40,000	36,000	42
GCG-50*	50	48	81	0.62	40,000	37,000	41
GCR-50*	50	48	84	0.62	40,000	37,000	43
GCRT-50*	50	48	89	0.61	50,000	45,000	54
†GCRX-50*	50	49	99	0.61	60,000	54,000	65
GCRX-55*	55	55	83	0.62	60,000	54,000	65
Short Models							
†GCBL-30R	30	29	65	0.60	32,000	29,000	32
GCRL-30R	30	29	55	0.60	32,000	29,000	32
†GCBL-40	40	38	68	0.57	40,000	36,000	41
GCRL-40	40	38	67	0.59	40,000	36,000	41
GCRL-50	50	50	81	0.62	40,000	40,000	43

Water connection is 3/4" on all models.

For 10-year tank and 10-year parts warranty, change "G" to "X" in model number (example: XCR-40).

All models approved for installation from sea level to 10,100 ft. elevation.

† Models ship with supplied insulation blanket

Specify when ordering propane (LP) gas.

‡ LP models not available on GCRH-40

*For optional side-mounted recirculating taps, add "L" to the suffix in the model number.

Model Number	Dimensions in Inches				
	A	B	C	D	E
Tall Models					
†GCB-30R	60 1/2	57	16	12-1/4	8
GCR-30R	60 1/2	57	18	12-1/4	8
‡GCRH-40	61-3/4	58-1/4	20	12-1/4	8
†GCB-40	61-3/4	58-1/4	18	12-1/4	8
GCR-40*	61-3/4	58-1/4	20	12-1/4	8
GCG-50*	60-3/4	57-1/4	21	12-1/4	8
GCR-50*	60-3/4	57-1/4	22	12-1/4	8
GCRT-50*	60-3/4	57-1/4	22	12-1/4	8
†GCRX-50*	65-1/2	61	22	13-1/2	8
GCRX-55*	59-3/4	55-1/4	24	13-1/2	8
Short Models					
†GCBL-30R	50 1/4	46 3/4	18	12	8
GCRL-30R	50 1/4	46 3/4	20	12	8
†GCBL-40	51-1/2	48	20	12	8
GCRL-40	51-1/2	48	22	12	8
GCRL-50	53-1/4	49-3/4	24	13-1/4	8

Model Number	Dimensions in Inches				Approx. Shipping Weight (lbs)
	F	*G	*H	Draft Hood Outlet	
Tall Models					
†GCB-30R	51-3/4	N/A	N/A	3 or 4	123
GCR-30R	51-3/4	N/A	N/A	3 or 4	132
‡GCRH-40	52	N/A	N/A	3 or 4	138
†GCB-40	52	N/A	N/A	3 or 4	130
GCR-40*	52	14-1/4	51-3/4	3 or 4	138
GCG-50*	50 1/2	14-1/4	50-1/2	3 or 4	148
GCR-50*	50-1/2	14-1/4	50-1/2	3 or 4	165
GCRT-50*	50-1/2	14-1/4	50-1/2	4	165
†GCRX-50*	54-1/4	14-1/4	54-1/4	4	182
GCRX-55*	48	14-1/4	48	4	185
Short Models					
†GCBL-30R	40	N/A	N/A	3 or 4	114
GCRL-30R	40	N/A	N/A	3 or 4	108
†GCBL-40	41-1/4	N/A	N/A	3 or 4	134
GCRL-40	41-1/4	N/A	N/A	3 or 4	135
GCRL-50	41-3/8	N/A	N/A	3 or 4	177

Water connection is 3/4" on all models.

For 10-year tank and 10-year parts warranty, change "G" to "X" in model number (example: XCR-40).

All models approved for installation from sea level to 10,100 ft. elevation.

† Models ship with supplied insulation blanket

Specify when ordering propane (LP) gas.

‡ LP models not available on GCRH-40

*For optional side-mounted recirculating taps, add "L" to the suffix in the model number.

RESIDENTIAL GAS

PROLINE® ENERGY SAVER ATMOSPHERIC VENT MOBILE HOME



Complies with HUD Standards for Manufactured Housing Installation

Gas Control Convertible for Natural and Propane Gas

- For flexibility to meet the varying needs of manufactured housing installations

Side-Mounted 3/4" Cold Water Inlet

- For flexibility to meet the varying needs of manufactured housing installations
- Top-mounted 3/4" hot water outlet

Green Choice® Gas Burner

- Patented eco-friendly burner design reduces NOx emissions by up to 33% and complies with Low-NOx emission requirements of less than 40 ng/l

CoreGard™ Anode Rod

Blue Diamond® Glass Coating

Enhanced-Flow Brass Drain Valve

Code Compliance

- Meets UBC, CEC and HUD National Codes.
- Meets the thermal efficiency and standby loss requirements of the U.S. Department of Energy and current edition of ASHRAE/IES 90.1
- Complies with the Federal Energy Conservation Standards effective April 16, 2015, in accordance with the Energy Policy and Conservation Act (EPCA), as amended

Design-Certified by CSA International

- Certified at 300 psi test pressure and 150 psi working pressure
- Listed according to ANSI Z21.10.1-CSA 4.1 standards governing storage tank-type gas water heaters

CSA Certified and ASME Rated T&P Relief Valve

6-Year Limited Tank and 6-Year Limited Tank Parts Warranty

- For complete information, consult written warranty or go to hotwater.com

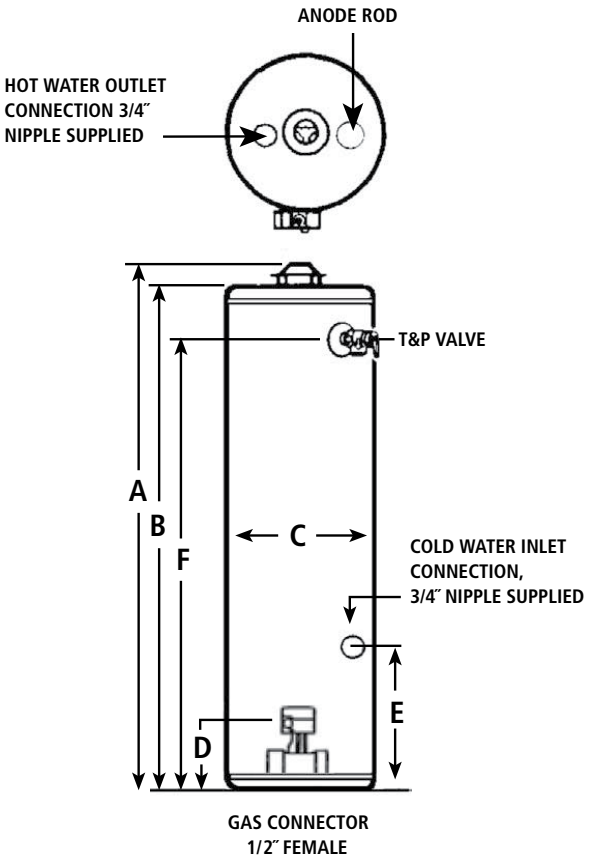

Model Number	Nominal Capacity	Rated Storage Volume	First Hour Rating (Gallons)	UEF	BTU Input Per Hour Natural Gas	BTU Input Per Hour Propane Gas	Recovery @ 90°F Rise Gallon Per Hour
FMHR-30	30	29	63	0.61	35,500	32,000	36
FMHR-40	40	38	59	0.58	35,500	32,000	36

Model Number	Dimensions in Inches						Draft Hood Outlet	Approx. Shipping Weight (lbs)
	A	B	C	D	E	F		
FMHR-30	61-1/2	58	18	13	14-1/4	52	3 or 4	129
FMHR-40	61-3/4	58-1/4	20	13	14-1/4	51-3/4	3 or 4	153

All models ship from factory for use with natural gas. A complete propane (LP) burner is supplied for converting to propane gas.

No option available for top T&P.

Certified from sea level to 10,100 ft. elevation.

PROLINE® ENERGY SAVER DIRECT VENT MOBILE HOME



Complies With HUD Standards For Manufactured Housing Installation

Gas Control Convertible for Natural and Propane Gas

- For flexibility to meet the varying needs of manufactured housing installations

Direct Vent Models Package with Bottom Intake Air Vent

- To draw all combustion make-up air from outside the structure

Optional Ducted Air Inlet Kit for Direct Vent Models

- For use when water heater is installed over a basement
- Provision for horizontal air inlet ducting

Side-Mounted 3/4" Cold Water Inlet

Green Choice® Gas Burner

- Patented eco-friendly burner design reduces NOx emissions by up to 33% and complies with Low-NOx emission requirements of less than 40 ng/J

DynaClean™ Diffuser Dip Tube

CoreGard™ Anode Rod

Enhanced-Flow Brass Drain Valve

Blue Diamond® Glass Coating

Code Compliance

- Meets UBC, CEC and HUD National Codes
- Meets the thermal efficiency and standby loss requirements of the U.S. Department of Energy and current edition of ASHRAE/IES 90.1
- Complies with the Federal Energy Conservation Standards effective April 16, 2015, in accordance with the Energy Policy and Conservation Act (EPCA), as amended

Design-Certified by CSA International

- Certified at 300 psi test pressure and 150 psi working pressure
- Listed according to ANSI Z21.10.1-CSA 4.1 standards governing storage tank-type gas water heaters

CSA Certified and ASME Rated T&P Relief Valve

6-Year Limited Tank and 6-Year Limited Parts Warranty

- For complete information, consult written warranty or go to hotwater.com



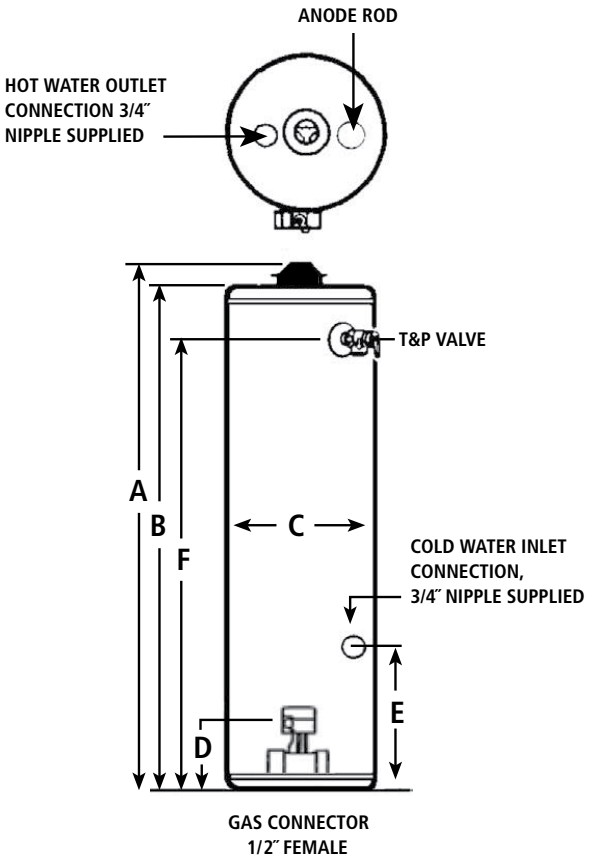

Model Number	Nominal Capacity	Rated Storage Volume	First Hour Rating (Gallons)	UEF	Btu Input Per Hour Natural Gas	Btu Input Per Hour Propane	Recovery @ 90°F Rise Gallon Per Hour	Vent Outlet
FMDV-30	30	29	60	0.61	30,000	29,000	31	3
FMDV-40	40	38	57	0.59	32,000	29,000	33	3
FMDV-50	50	47	67	0.56	40,000	37,000	39	3

Model Number	Dimensions in Inches						Approx. Shipping Weight (lbs)
	A	B	C	D	E	F	
FMDV-30	61	58	18	13	14-1/4	52-1/2	129
FMDV-40	61-3/4	58-3/4	20	13	14-1/4	52-1/4	153
FMDV-50	60	57	22	13	14-1/4	50	168

All models ship from the factory for use with natural gas, a complete propane burner is supplied for converting to propane gas.

No option available for top T&P.

Water connections-3/4" on all models.

All models are certified for installation from sea level to 5,400 ft. elevation.

RESIDENTIAL GAS

PROLINE® ULTRA-LOW NOx



The Electronic Gas Control Incorporates an LED Status Indicator that Monitors System Operation and Service Diagnostics

High UEFs

- Eco-Friendly non-CFC foam insulation, external heat traps and specially designed combustion chamber combine to produce a high UEF for maximum savings on operating costs

Green Choice® Gas Burner

- Enhanced Ultra-Low NOx burner complies with SCAQMD Rule 1121 and other air quality management districts with similar requirements for NOx emissions of less than 10 ng/l

DynaClean™ Diffuser Dip Tube

CoreGard™ Anode Rod

Push-Button Piezo Ignitor

Heat Trap Nipples

Blue Diamond® Glass Coating

Enhanced-Flow Brass Drain Valve

Code Compliance

- Meets UBC, CEC and HUD National Codes
- Meets the thermal efficiency and standby loss requirements of the U.S. Department of Energy and current edition of ASHRAE/IES 90.1
- Complies with the Federal Energy Conservation Standards effective April 16, 2015, in accordance with the Energy Policy and Conservation Act (EPCA), as amended

CSA Certified And ASME Rated T&P Valve

Design-Certified by CSA International

- Certified at 300 psi test pressure and 150 psi working pressure
- Listed according to ANSI Z21.10.1-CSA 4.1 standards governing storage tank-type gas water heaters

6-Year Limited Tank and Parts Warranty

- For complete information, consult written warranty or go to hotwater.com

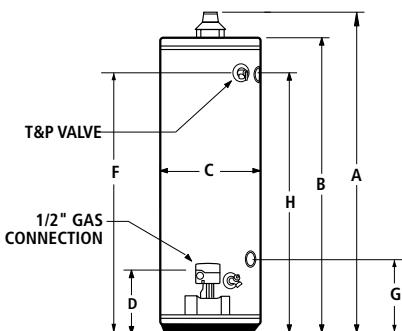
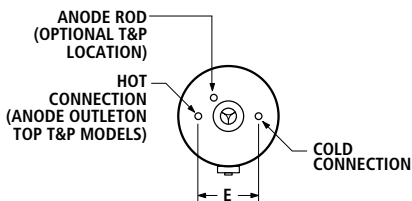

Maximum Hydrostatic Working Pressure: 150 PSI

Model Number	Nominal Capacity	Rated Storage Volume	First Hour Rating (Gallons)	UEF	BTU Input Natural Gas	Recovery @ 90°F Rise Gallon Per Hour	Approx. Shipping Weight (lbs)
Tall Models							
GUC-30	30	29	62	0.59	33,000	34	126
GUC-40	40	38	72	0.55	40,000	41	125
GUR-40	40	38	81	0.64	40,000	41	125
GUC-50	50	48	84	0.61	40,000	42	148
GUR-50	50	48	84	0.64	40,000	42	148
GURT-50L*	50	48	91	0.60	50,000	51	177
Short Models							
GURL-40	40	38	72	0.57	40,000	41	138

Model Number	Dimensions in Inches								Draft Hood Outlet
	A	B	C	D	E	F	G*	H*	
Tall Models									
GUC-30	61-3/4	58	16	12	8	51-3/4	N/A	N/A	3 or 4
GUC-40	62	58-1/4	18	12	8	52	N/A	N/A	3 or 4
GUR-40	62	58-1/4	20	12	8	52	N/A	N/A	3 or 4
GUC-50	60-3/4	57-1/4	20	12	8	50-1/2	N/A	N/A	3 or 4
GUR-50	60-3/4	57-1/4	22	12	8	50-1/2	N/A	N/A	3 or 4
GURT-50L*	61	57-1/2	22	12-1/4	8	50-1/2	12-1/4	50-1/2	4
Short Models									
GURL-40	51-1/2	47-3/4	22	12	8	41-1/4	N/A	N/A	3 or 4

All models may be ordered from the factory with top T&P.

*Side loop connections are standard on model (GURT-50L).

*All models approved for installation from sea level to 10,100 ft. elevation.

For 10-year tank and 10-year parts limited warranty, change "G" to "X" in model number (example: XUR-40).

RESIDENTIAL GAS

PROLINE® ULTRA-LOW NOx DIRECT VENT



Flammable Vapor Resistant/Direct Vent Sealed Combustion System

Durable, Ultra-Low NOx Burner Construction

Non-CFC Foam Insulation

- The tank is surrounded by a thick coat of non-CFC polyurethane foam to trap heat inside the tank, saving energy

3/4" Top Water Connections and Side Space Heating Connections

1/2" Gas Connection

Coregard™ Anode Rod

Blue Diamond® Glass Coating

Enhanced-Flow Brass Drain Valve

Green Choice® Gas Burner

- Complies with SCAQMD Rule 1121 and other air quality management districts with similar requirements for NOx emissions of less than 10 ng/J

Code Compliance

- Meets UBC, CEC and HUD National Codes
- Meets the thermal efficiency and standby loss requirements of the U.S. Department of Energy and current edition of ASHRAE/IES 90.1
- Complies with the Federal Energy Conservation Standards effective April 16, 2015, in accordance with the Energy Policy and Conservation Act (EPCA), as amended

CSA Certified And ASME Rated T&P Valve.

Design-Listed by CSA International

- Certified at 300 psi test pressure and 150 psi working pressure
- Listed according to ANSI Z21.10-1- CSA 4.1 standards governing storage tank-type gas water heaters

CSA Certified and ASME Rated T&P Relief Valve

6-Year Limited Tank and Parts Warranty

- For complete information, consult written warranty or go to hotwater.com



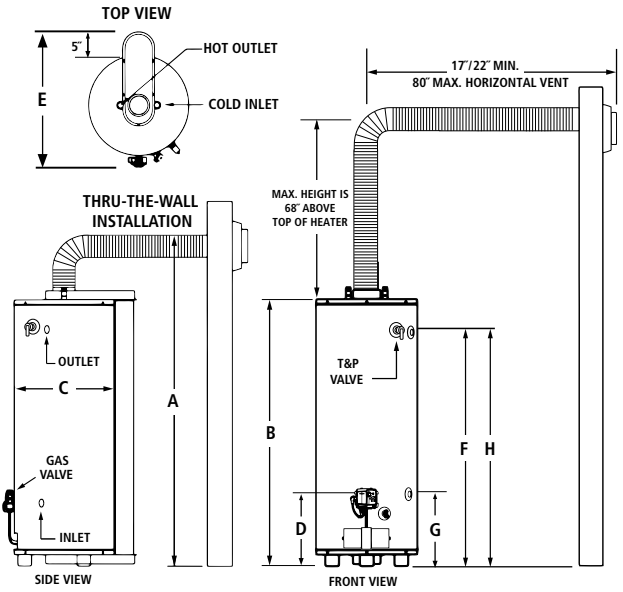

Model Number	Nominal Capacity	Rated Storage Volume	First Hour Rating (Gallons)	UEF	Recovery 90°F Rise Gallon Per Hour	BTU Input Per Hour
GDNL-40L	40	39	64	0.59	39	36,000
GDNT-50L	50	48	76	0.65	41	38,000

Model Number	Concentric Vent Connection	Dimensions in Inches				Approx. Shipping Weight (lbs)
		A	B	C	D	
GDNL-40L	3 or 5	65-1/4	50-1/2	22	13-1/2	179
GDNT-50L	3 or 5	73-1/2	58-1/2	22	13-1/2	193

Model Number	Dimensions in Inches			
	E	F	G	H
GDNL-40L	30	43-7/8	15	45
GDNT-50L	30	52-1/4	15	53

No option available for top T&P valve.

All models have 3/4" top water connections and comes standard with side loop fittings.

All models certified from sea level to 7,700 ft. elevation.

RESIDENTIAL GAS

PROLINE® ULTRA-LOW NO_x HIGH CAPACITY



Fully Automatic Controls with Safety Shutoff

Heavy Gauge Steel Jacket

Blue Diamond® Glass Coating

Foam Insulation

Ultra-Low NO_x Emissions

- Complies with SCAQMD Rule 1146.2 and other Air Quality Management Districts with similar requirements of 14 ng/J or 20 ppm

Easy-To-Install

- Completely factory-assembled
- Only gas, water and vent connections need to be made
- All connections are located in front and top of heaters for ease-of-installation and service

Coregard™ Anode Rod

- Our anode rods have a stainless steel core that extends the life of the anode rod allowing superior tank protection far longer than standard anode rods

Maximum Working Pressure

- 150 psi

Maximum Gas Inlet Pressure

- 14" W.C.

Code Compliance

- The Ultra-Low NO_x atmospheric vent residential gas water heater meets the thermal efficiency and standby loss requirements of the U. S. Department of Energy and Current Edition ASHRAE/IES 90.1

6-Year Limited Tank and Parts Warranty

- For complete information, consult written warranty or go to hotwater.com

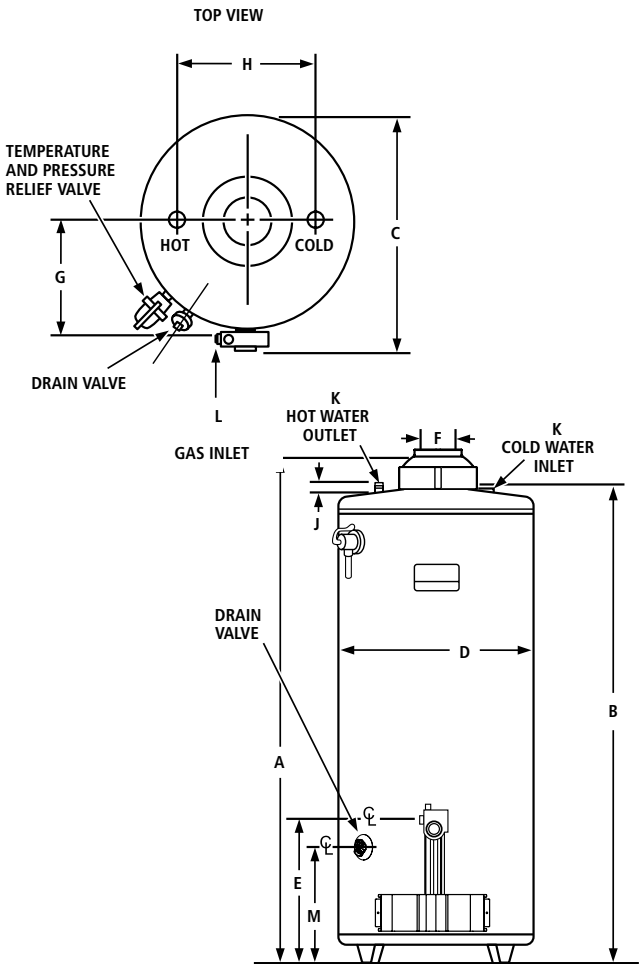

Model Number	Nominal Capacity	Rated Storage Volume	First Hour Rating (Gallons)	UEF	Recovery @ 90°F Rise Gallon Per Hour	BTU Input Per Hour
† GCN-75	74	71	102	0.64	81	75,100
GCN-100	98	95	120	0.58	82	75,100

Model Number	Dimensions in Inches					Approx. Shipping Weight
	A	B	C	D	E	
†GCN-75	62-1/16	58	29-1/2	25-1/4	15-7/8	285 lbs
GCN-100	70-1/2	66-1/2	30-15/16	27-3/4	15-3/16	350 lbs

*Recover rating based on 81% thermal efficiency.

**Recover rating based on 80% thermal efficiency.

†The GCN-75 comes standard with side loop fittings for use with hydronic heating applications.

RESIDENTIAL ELECTRIC

VOLTEX[®] HYBRID ELECTRIC HEAT PUMP



Increased Energy Efficiency

- Reduce water heating costs up to 73% compared to a standard electric water heater
- Up to a 3.45 Uniform Energy Factor (UEF) Rating conserves energy and meets ENERGY STAR[®] qualifications

Dual Voltage Capable

- 208/240 VAC 60Hz capable for use in almost any residential installation

Choice of Operating Modes

- Select from Efficiency, Hybrid or Electric modes to match heating requirements to environmental conditions and hot water demand. Hybrid mode automatically adjusts between compressor and element, depending upon heat requirements.
- Vacation mode reduces operating costs and provides freeze protection during extended absence.

Backup Electric Elements

- Long-lasting 4500W backup heating elements help heat water according to environmental conditions, demand, and the chosen operating mode.

Dry Fire Protection

- Control system checks to ensure the tank is full of water during start up to prevent dry firing the heating elements.

Electronic User Interface

- User-friendly electronic interface allows easy control of temperature setting, operating mode, and communicates diagnostics.
- Advanced diagnostics convey error messages for service purposes. The last four error messages are saved in the control system memory.

Other Features

- Ideal for basements or garage installations; the compressor transfers heat to the water while dehumidifying and cooling the ambient air
- Washable air filter is easily removed for routine cleaning
- Accessory Inlet/Outlet Duct Kit (Part number 100234320)

Code Compliance

- Meets IBC and HUD National Codes.
- Meets the thermal efficiency and standby loss requirements of the U.S. Department of Energy and current edition of ASHRAE/IES 90.1

10-Year Limited Warranty

- For complete information, consult written warranty or go to hotwater.com

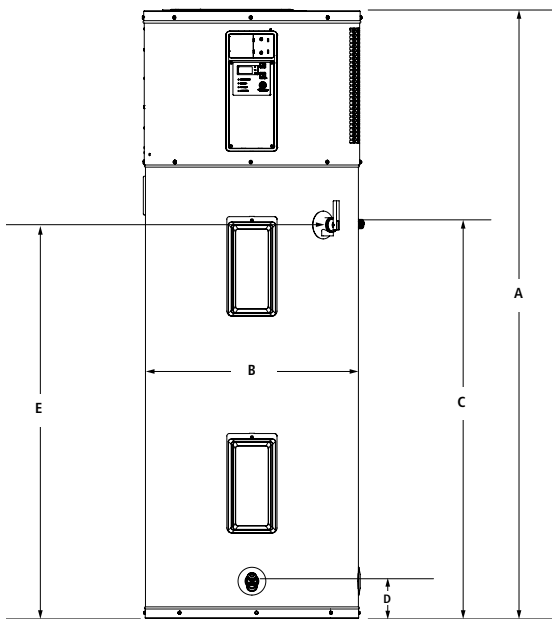

Model Number	Nominal Capacity	Rated Storage Volume	UEF	First Hour Rating (Gallons)	Approx. Shipping Weight (lbs)	Warranty Term
HPTU-50N	50	46	3.45	66	196	10
HPTU-66N	66	67	3.45	79	289	10
HPTU-80N	80	82	3.45	86	307	10

Model Number	Dimensions in Inches				
	A	B	C	D	E
HPTU-50N	63	22	40-5/8	3-3/4	40-1/2
HPTU-66N	61	27	38	4	38
HPTU-80N	69	27	46	4	46

Requires 30 amp breaker.
 Top T&P option not available on this model.

VOLTEX® HYBRID ELECTRIC HEAT PUMP



Increased Energy Efficiency

- Reduce water heating costs up to 73% compared to a standard electric water heater
- Up to a 3.45 Uniform Energy Factor (UEF) Rating conserves energy and meets ENERGY STAR® qualifications

Dual Voltage Capable

- 208/240 VAC 60Hz capable for use in almost any residential installation

Choice of Operating Modes

- Select from Efficiency, Hybrid or Electric modes to match heating requirements to environmental conditions and hot water demand. Hybrid mode automatically adjusts between compressor and element, depending upon heat requirements.
- Vacation mode reduces operating costs and provides freeze protection during extended absence

Backup Electric Elements

- Long-lasting 4500W backup heating elements help heat water according to environmental conditions, demand, and the chosen operating mode

Dry Fire Protection

- Control system checks to ensure the tank is full of water during start up to prevent dry firing the heating elements

Electronic User Interface

- User-friendly electronic interface allows easy control of temperature setting, operating mode, and communicates diagnostics
- Advanced diagnostics convey error messages for service purposes. The last four error messages are saved in the control system memory.

Other Features

- Ideal for basements or garage installations; the compressor transfers heat to the water while dehumidifying and cooling the ambient air
- Washable air filter is easily removed for routine cleaning
- Accessory Inlet/Outlet Duct Kit (Part number 100234320)

Code Compliance

- Meets IBC and HUD National Codes
- Meets the thermal efficiency and standby loss requirements of the U.S. Department of Energy and current edition of ASHRAE/IES 90.1

6-Year Limited Warranty

- For complete information, consult written warranty or go to hotwater.com

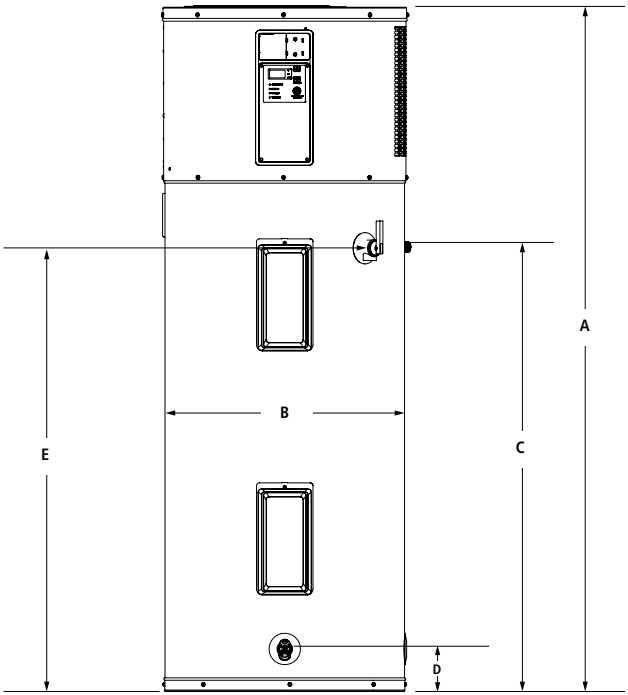

Model Number	Nominal Capacity	Rated Storage Volume	UEF	First Hour Rating (Gallons)	Approx. Shipping Weight (lbs)	Warranty Term
FPTU-50	50	46	3.42	66	196	6
FPTU-66	66	67	3.35	79	289	6
FPTU-80	80	82	3.45	84	307	6

Model Number	Dimensions in Inches				
	A	B	C	D	E
FPTU-50	63	22	40-5/8	3-3/4	40-1/2
FPTU-66	61	27	38	4	38
FPTU-80	69	27	46	4	46

Requires 30 amp breaker.
 Top T&P option not available on this model.

RESIDENTIAL ELECTRIC

PROLINE® XE ELECTRONIC DISPLAY



LOW LEAD COPPER



ELECTRONIC USER INTERFACE

- Touchscreen display
- Multiple operating modes help save money
 - Energy Saver and vacation modes available
- Diagnostic feedback
- Dry fire protection

SMART PORT MODULE

- Allows for grid connectivity via optional CTA-2045 port adapter and 3rd party communication module
- Can provide Demand Response, Energy Storage and Time of Use saving benefits depending on local utility services offered.

ENHANCED HEATING ELEMENTS

- Dual 5500 watt elements for the fastest recovery and reliable operation
- Incoloy stainless steel elements last longer than standard copper elements

ENHANCED-FLOW BRASS DRAIN VALVE

CODE COMPLIANCE

- Meets UBC, CEC and HUD National Codes
- Meets the thermal efficiency and standby loss requirements of the U.S. Department of Energy and current edition of ASHRAE/IES 90.1
- Complies with the Federal Energy Conservation Standards effective April 16, 2015, in accordance with the Energy Policy and Conservation Act (EPCA), as amended

DESIGN-LISTED BY UNDERWRITERS LABORATORIES

- Certified at 300 psi test pressure and 150 psi working pressure
- Listed according to UL174 standards governing storage tank-type water heaters

10-YEAR LIMITED TANK AND PARTS WARRANTY

- For complete information, consult written warranty or go to hotwater.com

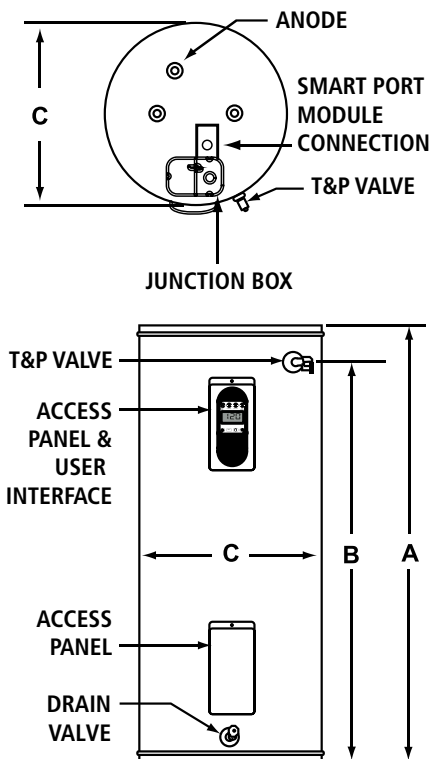

Model Number	Nominal Capacity	Rated Storage Volume	First Hour Rating (Gallons)	UEF	Recovery @ 90°F Rise Gallon Per Hour	Approx. Shipping Weight (lbs)
Tall Models						
PXGT-40	40	36	59	0.93	25	118
PXGT-50	50	45	67	0.93	25	134
PXGT-55	55	55	72	0.92	25	145
Short Models						
PXGS-40	40	37	54	0.92	25	109
PXGS-50	50	46	66	0.95	25	161

Model Number	Element Wattage 240V		Dimensions in Inches		
	Standard	Maximum	A	B	C
Tall Models					
PXGT-40	5500	6000	61-1/4	53-1/4	20
PXGT-50	5500	6000	60-1/2	51-1/4	22
PXGT-55	5500	6000	56-1/2	48-1/2	24
Short Models					
PXGS-40	5500	6000	49 3/4	40-3/4	20-1/2
PXGS-50	5500	6000	49-1/4	40-1/4	23

3/4" water connections on 8" center.

Only available for 240V or 208V applications. Equipped as dual element only, no single element configurations available. Minimum wattage available is 4,500 watt elements. Dimensions and specifications subject to change without notice in accordance with our policy of continuous product improvement.

PROLINE® ELECTRONIC THERMOSTAT



Smart Port Module

- Allows for grid connectivity via optional CTA-2045 port adapter and 3rd party communication module.
- Can provide Demand Response, Energy Storage and Time of Use saving benefits depending on local utility services offered.

Energy Efficient

- Eco-friendly non-CFC foam insulation, heat traps and other features combine to yield a high Uniform Energy Factor to maximize savings

Dynaclean™ Diffuser Dip Tube

- Helps reduce lime and sediment buildup and maximizes hot water output. Made from long-lasting PEX cross-linked polymer.

Coregard™ Anode Rod

- Our anode rods have a stainless steel core that extends the life of the anode rod allowing superior tank protection far longer than standard anode rods

Blue Diamond® Glass Coating

Enhanced-Flow Brass Drain Valve

Code Compliance

- Meets UBC, CEC and HUD National Codes.
- Meets the thermal efficiency and standby loss requirements of the U.S. Department of Energy and current edition of ASHRAE/IES 90.1
- Complies with the Federal Energy Conservation Standards effective April 16, 2015, in accordance with the Energy Policy and Conservation Act (EPCA), as amended

CSA Certified And ASME Rated T&P Relief Valve

- Certified at 300 psi test pressure and 150 psi working pressure
- Listed according to UL 174 standards governing storage tank-type electric water heaters

6-Year Limited Tank and Parts Warranty

- For complete information, consult written warranty or go to hotwater.com

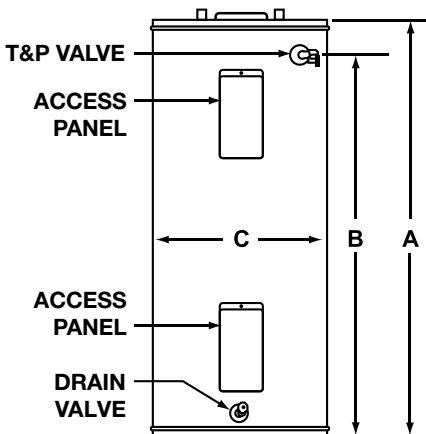
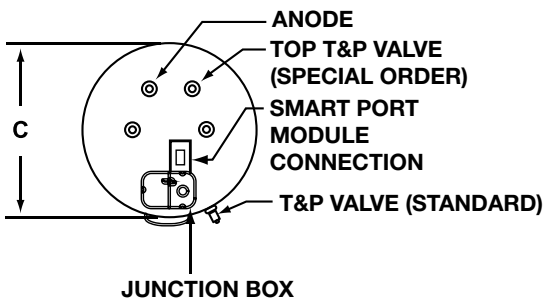

Model Number	Nominal Capacity	Rated Storage Volume	First Hour Rating (Gallons)	UEF	Recovery @ 90°F Rise Gallon Per Hour	Approx. Shipping Weight (lbs)
Tall Models						
EGT-40	40	36	51	0.92	25	118
EGT-50	50	45	56	0.93	25	134
Short Models						
EGS-40	40	37	51	0.92	25	109
EGS-50	50	46	58	0.92	25	161

Model Number	Element Wattage 240V		Dimensions in Inches		
	Standard	Maximum	Height to Top of Tank	Height to T&P	Diameter
Tall Models					
EGT-40	4500	5500	61-1/4	53-1/4	20
EGT-50	4500	5500	61-1/2	51-1/4	22
Short Models					
EGS-40	4500	5500	49-3/4	40-3/4	20-1/2
EGS-50	4500	5500	49-1/4	40-1/4	23

3/4" water connections on 8" center.

All models are available with top-mounted T&P valve (Optional).

Only available for 240V or 208V applications.

208V is only available with 4,500 watt elements.

Equipped as dual element only, no single element configurations available.

Minimum wattage available is 4,500 watt elements.

Dimensions and specifications subject to change without notice in accordance with our policy of continuous product improvement.

RESIDENTIAL ELECTRIC

PROLINE® MASTER STANDARD



Commercial-Grade Heating Elements

- Dual 4500 watt elements for the fastest recovery and reliable operation
- Long-lasting dual stainless steel elements last longer than standard copper elements

High Uniform Energy Factors (UEFs)

DynaClean™ Diffuser Dip Tube

CoreGard™ Anode Rod

- ProLine® Master products have increased anode protection with either longer or multiple anodes, depending on model

Code Compliance

- Meets UBC, CEC and HUD National Codes
- Meets the thermal efficiency and standby loss requirements of the U.S. Department of Energy and current edition of ASHRAE/IES 90.1
- Complies with the Federal Energy Conservation Standards effective April 16, 2015, in accordance with the Energy Policy and Conservation Act (EPCA), as amended

Approved for Manufactured Housing

- All residential electric water heaters are compliant with HUD standards for mobile homes/ manufactured housing

Design-Listed by Underwriters Laboratories

- Certified at 300 psi test pressure and 150 psi working pressure
- Listed according to UL 174 standards governing storage tank-type electric water heaters

8-Year Limited Tank and Parts Warranty

- For complete information, consult written warranty or go to hotwater.com

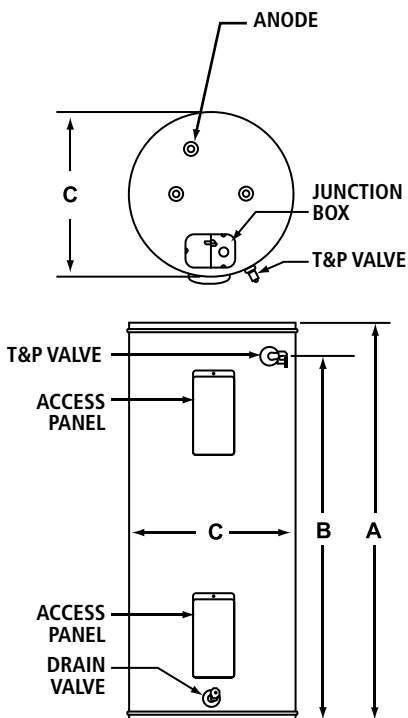

Model Number	Nominal Capacity	Rated Storage Volume	First Hour Rating (Gallons)	UEF	Recovery @ 90°F Rise Gallon Per Hour
Tall Models					
HNT-40	40	36	53	0.92	21
HNT-50	50	46	62	0.92	21
HNT-50W	50	46	45	0.88	11
HNT-55	55	55	72	0.93	21
Short Models					
HNS-40	40	37	55	0.92	21
HNS-40W	40	37	41	0.88	18
HNS-50	50	46	57	0.92	21

Model Number	Element Wattage 240V			Dimensions in Inches			Approx. Shipping Weight (lbs)
	Standard	Minimum	Maximum	A	B	C	
Tall Models							
HNT-40	4500	3500	6000	61-1/4	53-1/4	18	118
HNT-50	4500	@ 3000	6000	60-1/2	51-1/4	20-1/2	125
HNT-50W	-	1000	2500	60-1/2	51-1/4	20-1/2	125
HNT-55	4500	2500	6000	56-1/2	48-1/2	24	145
Short Models							
HNS-40	4500	@ 4500	6000	50	40-3/4	20-1/2	109
HNS-40W	-	1000	4000	50	40-3/4	20-1/2	109
HNS-50	4500	2500	6000	49-3/4	40-3/8	23	161

Male 3/4" water connections on 8" center.

Models requiring a lower wattage than what is listed in the minimum wattage column and showing the @ symbol, will change to a "W" suffix model number.

"W" suffix models are available down to 1kW.

(example: HNS-40 using 4,000 watt elements or less will become "HNS-40W").

Dimensions and specifications subject to change without notice in accordance with our policy of continuous product improvement.

RESIDENTIAL ELECTRIC

PROLINE® STANDARD



Enhanced Heating Elements

- Dual 4500 watt elements for the fastest recovery and reliable operation
- Incoloy stainless steel lower element lasts longer than standard copper elements

High Uniform Energy Factors (UEFs)

DynaClean™ Diffuser Dip Tube

CoreGard™ Anode Rod

Code Compliance

- Meets UBC, CEC and HUD National Codes
- Meets the thermal efficiency and standby loss requirements of the U.S. Department of Energy and current edition of ASHRAE/IES 90.1
- Complies with the Federal Energy Conservation Standards effective April 16, 2015, in accordance with the Energy Policy and Conservation Act (EPCA), as amended

Approved for Manufactured Housing

- All residential electric water heaters are compliant with HUD standards for mobile homes/ manufactured housing

Design-Listed by Underwriters Laboratories

- Certified at 300 psi test pressure and 150 psi working pressure
- Listed according to UL 174 standards governing storage tank-type electric water heaters

6-Year Limited Tank and Parts Warranty

- For complete information, consult written warranty or go to hotwater.com

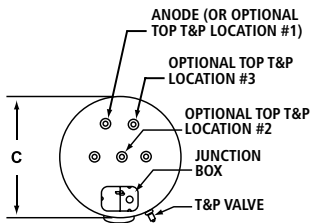
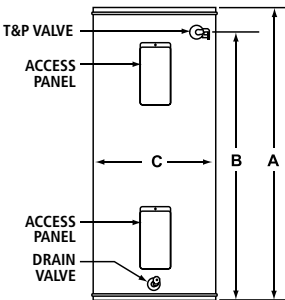

Model Number	Nominal Capacity	Rated Storage Volume	First Hour Rating (Gallons)	UEF	Element Wattage 240V		
					Standard	Minimum	Maximum
Tall Models							
ENT-30†	30	27	48	0.89	4500	1000	6000
ENT-40†	40	36	53	0.92	4500	3500	6000
ENT-50†	50	46	62	0.92	4500	@ 3000	6000
ENT-50W†	50	46	45	0.88	-	1000	2500
ENT-55†	55	55	72	0.93	4500	2500	6000
Short Models							
ENSB-30*	30	27	50	0.90	4500	1000	6000
ENS-30†	30	27	47	0.89	4500	1000	6000
ENS-40†	40	37	55	0.92	4500	@ 4500	6000
ENS-40W†	40	37	41	0.88	-	1000	4000
ENS-50†	50	46	57	0.92	4500	2500	6000
Lowboy Top Connect Models							
ENLB-30*†	28	26	43	0.89	4500	1000	6000
ENL-30†	28	26	44	0.90	4500	1000	6000
ENL-36†	36	33	51	0.92	4500	@ 4500	6000
ENL-36W†	36	33	37	0.89	-	1000	4000
ENL-40†	38	35	50	0.89	4500	1000	6000
ENLB-40*†	38	35	51	0.92	4500	@ 4500	6000
ENLB-40W*†	38	35	38	0.90	-	1000	4000
ENLB-50*†	48	44	60	0.93	4500	@ 4000	6000
ENLB-50W*†	48	44	40	0.91	-	1000	3500
ENL-50†	51	48	51	0.92	4500	4000	6000

Model Number	Recovery @ 90°F Rise Gallon Per Hour	Dimensions in Inches			Approx. Shipping Weight (lbs)
		A	B	C	
Tall Models					
ENT-30†	21	46-1/2	39-1/2	19	95
ENT-40†	21	61-1/4	53-1/4	18	118
ENT-50†	21	60-1/2	51-1/4	20-1/2	125
ENT-50W†	11	60-1/2	51-1/4	20-1/2	125
ENT-55†	21	56-1/2	48-1/2	24	145
Short Models					
ENSB-30*	21	39	30-1/2	20	95
ENS-30†	21	39-3/4	30-1/2	22	94
ENS-40†	21	49-3/4	40-3/4	20-1/2	109
ENS-40W†	18	49-3/4	40-3/4	20-1/2	109
ENS-50†	21	49-1/4	40-3/8	23	161
Lowboy Top Connect Models					
ENLB-30*†	21	30	21-3/4	20	90
ENL-30†	21	31 1/4	21-3/4	24	115
ENL-36†	21	32	24	24	118
ENL-36W†	18	32	24	24	118
ENL-40†	21	33 1/2	24	26	118
ENLB-40*†	21	32	24	23	118
ENLB-40W*†	18	32	24	23	118
ENLB-50*†	21	34	25	26-1/2	172
ENLB-50W*†	16	34	25	26-1/2	172
ENL-50†	21	36	25	26-1/2	172

Male 3/4" water connections on 8" center. *Models ship with supplied insulation blanket. †For 10-year tank and 10-year parts warranty, change "E" to "P" in the model number (example: ENT-30 becomes PNT-30). Models requiring a lower wattage than what is listed in the minimum wattage column and showing the @ symbol, will change to a "W" suffix model number. "W" suffix models are available down to 1kW. (example: ENS-40 using 4,000 watt elements or less will become "ENS-40W"). Top T&P is not available on the 10 year lowboy models. Dimensions and specifications subject to change without notice in accordance with our policy of continuous product improvement.

RESIDENTIAL ELECTRIC

PROLINE® 80 GALLON ELECTRIC



Smart Port Module

- Allows for grid connectivity via optional CTA-2045 port adapter and 3rd party communication module.
- Can provide Demand Response, Energy Storage and Time of Use saving benefits depending on local utility services offered.

Energy Efficient

- Eco-friendly non-CFC foam insulation, heat traps and other features combine to yield a high Uniform Energy Factor to maximize savings

Dynaclean™ Diffuser Dip Tube

- Helps reduce lime and sediment buildup and maximizes hot water output. Made from long-lasting PEX cross-linked polymer.

Coregard™ Anode Rod

- Our anode rods have a stainless steel core that extends the life of the anode rod allowing superior tank protection far longer than standard anode rods

Blue Diamond® Glass Coating

Enhanced-Flow Brass Drain Valve

Code Compliance

- Meets UBC, CEC and HUD National Codes.
- Meets the thermal efficiency and standby loss requirements of the U.S. Department of Energy and current edition of ASHRAE/IES 90.1
- Complies with the Federal Energy Conservation Standards effective April 16, 2015, in accordance with the Energy Policy and Conservation Act (EPCA), as amended

CSA Certified And ASME Rated T&P Relief Valve

- Certified at 300 psi test pressure and 150 psi working pressure
- Listed according to UL 174 standards governing storage tank-type electric water heaters

6 & 10-Year Limited Tank and Parts Warranty

- For complete information, consult written warranty or go to hotwater.com

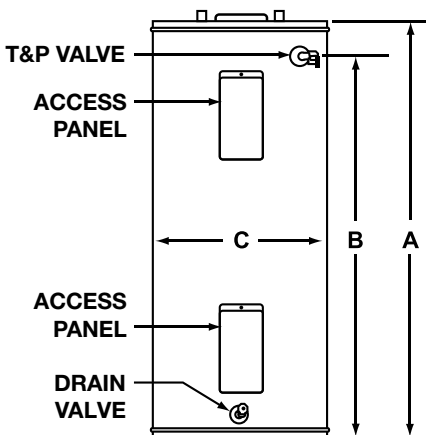
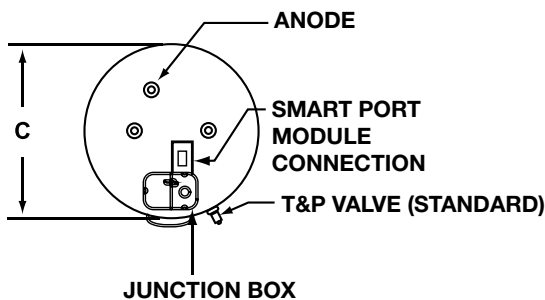

Model Number	Nominal Capacity	Rated Storage Volume	First Hour Rating (Gallons)	UEF	Recovery @ 90°F Rise Gallon Per Hour	Approx. Shipping Weight (lbs)
High Capacity 6-Year Warranty Model						
EGR-80	80	78	80	0.93	21	198
High Capacity 10-Year Warranty Model						
PGR-80	80	78	80	0.93	21	198

Model Number	Element Wattage 240V		Dimensions in Inches		
	Standard	Maximum	Height to Top of Tank	Height to T&P	Diameter
High Capacity 6-Year Warranty Model					
EGR-80	4500	5500	64-1/2	56	26
High Capacity 10-Year Warranty Model					
PGR-80	4500	5500	64-1/2	56	26

3/4" water connections on 8" center.

Only available for 240V or 208V applications.

208V is only available with 4,500 watt elements.

Equipped as dual element only, no single element configurations available.

Minimum wattage available is 4,500 watt elements.

Dimensions and specifications subject to change without notice in accordance with our policy of continuous product improvement.



Approved for Manufactured Housing

- All residential electric water heaters are compliant with HUD standards for mobile homes/ manufactured housing

Side Water Connections

- For ease of installation in mobile home applications

CoreGard™ Anode Rod

- Our anode rods have a stainless steel core that extends the life of the anode rod allowing superior tank protection far longer than standard anode rods

Long-Lasting Heating Elements

- Screw-in, direct immersion, 3500W/240V or 3000W/120V heating elements for maximum efficiency

Blue Diamond® Glass Coating

Enhanced-Flow Brass Drain Valve

- Our residential water heaters have a solid brass, tamper resistant, enhanced-flow, ball type, drain valve
- Uses a standard female hose fitting that allows for fast and easy draining during maintenance

CSA Certified and ASME Rated T&P Relief Valve

Code Compliance

- Meets UBC, CEC and HUD National Codes
- Meets the thermal efficiency and standby loss requirements of the U.S. Department of Energy and current edition of ASHRAE/IES 90.1
- Complies with the Federal Energy Conservation Standards effective April 16, 2015, in accordance with the Energy Policy and Conservation Act (EPCA), as amended

Design-Listed by Underwriters Laboratories

- Certified at 300 psi test pressure and 150 psi working pressure
- Listed according to UL 174 standards governing storage tank-type electric water heaters

6-Year Limited Tank and Parts Warranty

- For complete information, consult written warranty or go to hotwater.com

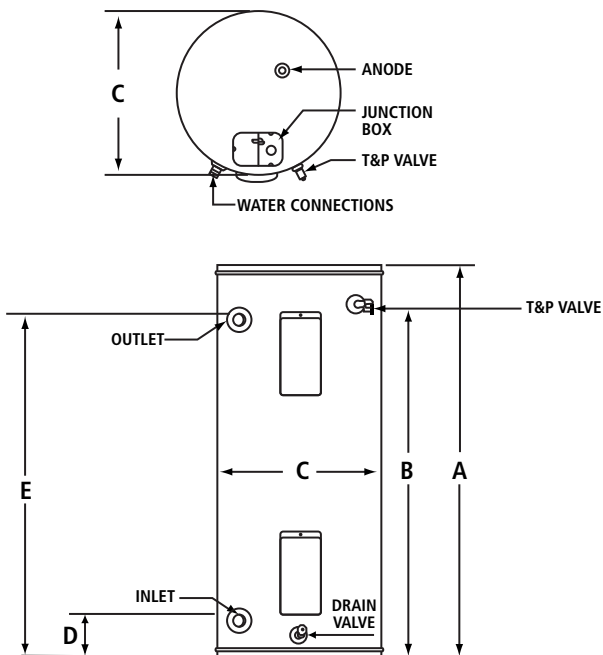

Model Number	Nominal Capacity	Rated Storage Volume	First Hour Rating (Gallons)	UEF	Recovery @ 90°F Rise Gallon Per Hour	Voltage
EMHT-30	30	27	50	0.90	14	120
EMHT-30	30	27	50	0.90	16	240
EMHT-30	30	27	50	0.90	21	240
EMHS-40W	40	36	40	0.91	14	120
EMHS-40W	40	36	40	0.91	16	240
EMHS-40	40	36	54	0.95	21	240
EMHL-30*	28	26	47	0.90	14	120
EMHL-30*	28	26	47	0.90	16	240
EMHL-30*	28	26	47	0.90	21	240

Model Number	Wattage		Dimensions in Inches		Approx. Shipping Weight (lbs)
	Upper Element	Lower Element	Height to Top of Heater	Diameter	
EMHT-30	3000	3000	46-3/4	19	98
EMHT-30	3500	3500	46-3/4	19	98
EMHT-30	4500	4500	46-3/4	19	98
EMHS-40W	3000	3000	50	22	109
EMHS-40W	3500	3500	50	22	109
EMHS-40	4500	4500	50	22	109
EMHL-30*	3000	3000	30	22	96
EMHL-30*	3500	3500	30	22	96
EMHL-30*	4500	4500	30	22	96

*Models ship with supplied insulation blanket.

Models may have limited element options due to element size or other restrictions.

3/4" water connections. Available with side T&P only.

Dimensions and specifications subject to change without notice in accordance with our policy of continuous product improvement.

RESIDENTIAL ELECTRIC

PROLINE® SPECIALTY ELECTRIC



LOWBOY



TABLE TOP



COMPACT



POINT-OF-USE

Approved For Manufactured Housing

- All residential electric water heaters are compliant with HUD standards for mobile homes/manufactured housing

Table-Top

- Features a convenient flat porcelain surface at 36" height, providing extra "counter space" wherever installed.
- All plumbing and electrical connections are made through the back of the water heater. This heater is equipped with a PEX cross-linked polymer dip tube

Point-of-Use

- Designed for low-demand, such as office lavatories or buildings with remote restrooms

Compact

- Side-mounted plumbing and electrical connections (optional top-mounted water connections for field conversion)
- Designed for installation under a counter, in a crawl space or in other tight spaces

Code Compliance

- Meets UBC, CEC and HUD National Codes
- Meets the thermal efficiency and standby loss requirements of the U.S. Department of Energy and current edition of ASHRAE/IES 90.1
- Complies with the Federal Energy Conservation Standards effective April 16, 2015, in accordance with the Energy Policy and Conservation Act (EPCA), as amended

Design-Listed By Underwriters Laboratories

- Certified at 300 psi test pressure and 150 psi working pressure
- Listed according to UL 174 standards governing storage tank-type electric water heaters

6-Year Limited Tank And Parts Warranty

- For complete information, consult written warranty or go to hotwater.com

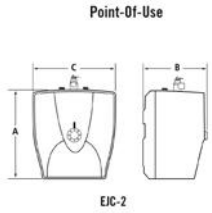
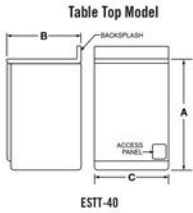
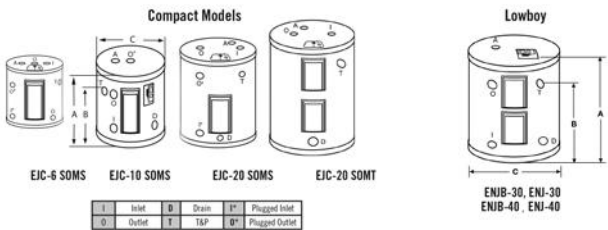

Model Number	Nominal Capacity	Rated Storage Volume	First Hour Rating (Gallons)	UEF	Element Wattage	
					Standard	Maximum
Compact Models					120V	240V
EJC-6	6	6	N/A	N/A	1650	3000
EJC-10	10	9	N/A	N/A	1650	6000
EJCS-20	19	17	N/A	N/A	2500	6000
EJCT-20	19.9	18	N/A	N/A	2500	6000
Lowboy Side-Connect Model					240V	
ENJB-30*	28	26	47	0.90	4500	6000
ENJ-30	28	26	43	0.91	4500	6000
ENJB-40*	38	35	57	0.94	4500	6000
ENJB-40W*	38	35	38	0.91	-	4000
ENJ-40	38	35	54	0.93	4500	6000
ENJ-40W	38	35	38	0.91	-	4000
Table Top Model					240V	
ENTT-38	38	35	55	0.90	4500	5500
Point-Of-Use-Models					120V	
EMT-2.5	2.5	2.6	N/A	N/A	1440 @ 120V	
EMT-4	4	3.8	N/A	N/A	1440 @ 120V	
EMT-6	6	5.9	N/A	N/A	1440 @ 120V	

Model Number	Recovery @ 90°F Rise Gallons Per Hour	Dimensions in Inches			Approx. Shipping Weight (lbs)
		A	B	C	
Compact Models					
EJC-6	8	15-1/4	10-3/4	14-1/4	35
EJC-10	8	18-1/4	12-1/4	16	41
EJCS-20	11	24-3/4	18-5/8	18	68
EJCT-20	11	31-5/8	25-3/4	16	68
Lowboy Side-Connect Model					
ENJB-30*	21	30	21-3/4	22	101
ENJ-30	21	31-1/4	21-3/4	24	115
ENJB-40*	21	31-3/4	24	24	118
ENJB-40W*	18	31-3/4	24	24	118
ENJ-40	21	33-1/2	24	26	118
ENJ-40W	18	33-1/2	24	26	118
Table Top Model					
ENTT-38	21	36	24	25	150
Point-Of-Use-Models					
EMT-2.5	7	18-1/2	13-1/4	12 1/4	17
EMT-4	7	23 1/4	13-1/4	12 1/4	20
EMT-6	7	24 1/4	16	15	24

*Models ship with a supplied insulation blanket.
 When ordering models ENJ-40 or ENJB-40 the model number will change for wattages of 4kW to 1kW. The new model number will include a "W" suffix (example: ENJB-40W)
 Dimensions and specifications subject to change without notice in accordance with our policy of continuous product improvement.

RESIDENTIAL

PUMP TANKS



Multiple Head Construction Adds Structural Strength and More Capacity within the Same Diameters

- Interior powder coating is permanently bonded to the tank shell for ultimate protection on the water side of the tank
- Butyl rubber parabolic diaphragm
- Positive lock retention system controls compression in the diaphragm connection, eliminating air loss or water leaks in tank
- Electrostatically applied powder-coated exterior for maximum sunlight (UV) resistance with zinc phosphate undercoat for highest corrosion resistance
- Corrosion-resistant metal air valve
- Rust Guard No-weld steel base
- 5-year limited warranty

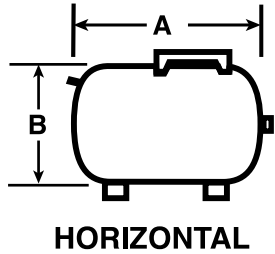
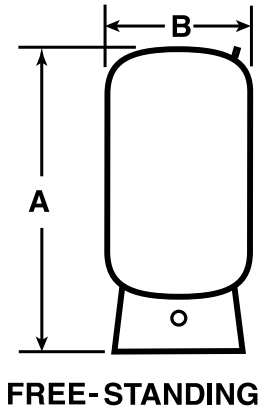
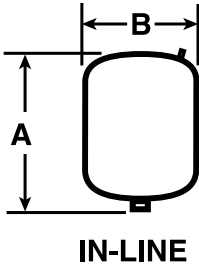

Model Number	Volume (Gallons)	Connecting NPT Size	Dimensions in Inches			Weight (lbs.)
			Overall Height -A	To Center of Water Inlet	Diameter-B	
PMI (Inline) and PM (Free-Standing) Series						
PMI-2	2.0	3/4 (M)	10-3/16	-	8-1/4	5
PMI-5	4.6	3/4 (M)	14-3/4	-	11	9
PMI-7	7.3	3/4 (M)	21-1/16	-	11	14
PMI-14	13.9	1 (M)	21-1/16	2	15-3/8	24
PM-14	13.9	1 (F)	24-15/16	2	15-3/8	24
PM-20	19.9	1 (F)	32-3/8	2	15-3/8	34
PM-26	25.9	1 (F)	39-9/16	2	15-3/8	43
PM-32	31.8	1 (F)	47-1/4	2	15-3/8	52
PM-45	45.2	1-1/4 (F)	36-9/16	2-1/2	22	65
PM-65	65.1	1-1/4 (F)	48-5/8	2-1/2	22	90
PM-85	84.9	1-1/4 (F)	60-11/16	2-1/2	22	114
PM-86	83.5	1-1/4 (F)	46	2-1/2	26	116
PM-119	115.9	1-1/4 (F)	61-5/16	2-1/2	26	161
Horizontal Series			Length-A		Diameter-B	
PMH-7	7.3	3/4 (M)	12-7/8	-	11	16
PMH-14	13.9	1 (M)	18-1/4	-	15-3/8	25
PMH-20	19.9	1 (M)	18-1/4	-	15-3/8	36

NOTE: M-Male connection
 F-Female connection
 All models 38 psi pre-charge

RESIDENTIAL

EXPANSION TANKS



Interior Powder Coating is Permanently Bonded to the Tank Shell for Ultimate Protection on the Inside of the Tank

Butyl Rubber Parabolic Diaphragm

Positive Lock Retention System Controls Compression in the Diaphragm Connection, Eliminating Air Loss or Water Leaks in Tank

Projection Welded Air Valve

5-Year Limited Warranty on PMC Expansion Tanks

1-Year Limited Warranty on Hydronic Expansion Tanks



When used in potable applications

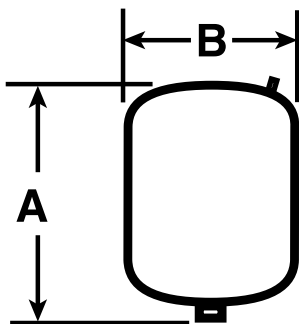

Model Number	Maximum (psig) Working Pressure	Tank Volume (Gallons)	Maximum Accepted Volume (Gallons)		
			20 psi	40 psi	60 psi
PMC-Series (Potable Expansion Tanks - 5-Year Limited Warranty)					
PMC-10	150	9.25	7.80	6.55	5.25
PMET-Series (Hydronic Expansion Tanks - 1-Year Limited Warranty)					
PMET-2	100	1.96	1.53	N/A	N/A
PMET-5	100	4.55	3.75	N/A	N/A
PMET-7	100	7.30	4.60	N/A	N/A
PMET-14	100	14.6	10.5	N/A	N/A

Model Number	Connection NPT Size	Dimensions in Inches		Weight (lbs)
		Overall Height - A	Diameter - B	
PMC-Series (Potable Expansion Tanks - 5-Year Limited Warranty)				
PMC-10	3/4	15-1/2	15-3/8	18
PMET-Series (Hydronic Expansion Tanks - 1-Year Limited Warranty)				
PMET-2	1/2	10-3/16	8-1/4	5
PMET-5	1/2	14-3/4	11	9
PMET-7	1/2	21-1/16	11	14
PMET-14	1/2	23-1/2	15-3/8	25

All PMC models 38 psi pre-charge.

All PMET models 12 psi pre-charge.

RESIDENTIAL TANKLESS

PROLINE® XE WITH X3™ SCALE PREVENTION TECHNOLOGY



ANSI Z21.10.3 • CSA 4.3

X3 Scale Prevention Technology (Patent Pending)

- Extends life of unit up to 3 times longer
- Eliminates need for isolation valves
- No annual descaling required
- No conditioning period required when using new copper pipe
- Maintains like-new performance longer

Integrated Recirculation Pump

- Title 24 Compliant

ENERGY STAR® Qualified

Field Convertible From Natural Gas To Propane

Dual Stainless Steel Heat Exchangers Ultra-Low NOx Emissions

- Complies with SCAQMD Rule 1146.2 NOx Emission Requirements Of 14 ng/J or 20 PPM

EASY-LINK™ System

Qualified As Lead Free Under The Safe Drinking Water Act

Safety Features

- Exhaust & Water Temperature Safety Control
- Overheat Cut-Off Fuse

Internal Freeze Protection System

Operates With 1/2-Inch Gas Line

- Includes 1/2-inch gas connection

Power Direct Vent Design

- Category IV venting can be used
- Exhaust, 2" PVC pipe up to 60 equivalent feet or 3" PVC pipe up to 150 equivalent feet
- Provides flexible venting with PVC, CPVC, polypropylene, or ABS Pipe for Intake and Exhaust (solid core only).

Warranty

- No hard water exclusions
- 15-year limited warranty on heat exchanger in residential applications
- 1-year limited warranty on heat exchanger in commercial applications
- 5-year limited warranty on all parts

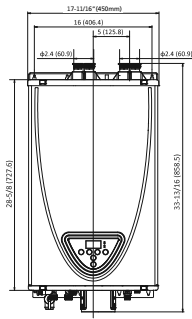

FRONT

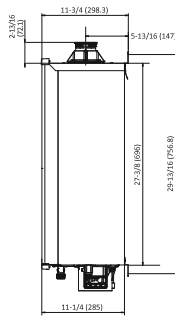

SIDE

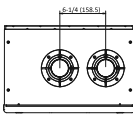
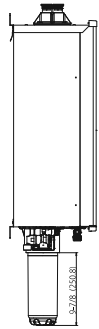

TOP

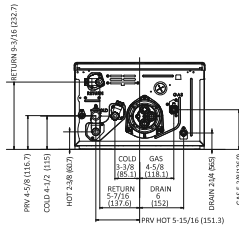

BOTTOM

Model Number*	Type*	Gas Consumption Input		Inlet Gas Pressure**		UEF
		Minimum BTU/H	Maximum BTU/H	Minimum in. W.C.	Maximum in. W.C.	
AT-160X3P	Natural	9,000	160,000	3.5	10.5	0.93
AT-180X3P	Natural	9,000	180,000	3.5	10.5	0.93
AT-199X3P	Natural	9,000	199,000	3.5	10.5	0.93

Maximum GPM***	Hot/Cold Connections	Gas Connection	Dimensions in Inches			Approx. Shipping Weight (lbs)
			Height	Width	Depth	
6.5	3/4" NPT	1/2" NPT	28-5/8	17-11/16	11-3/4	80
8	3/4" NPT	1/2" NPT	28-5/8	17-11/16	11-3/4	80
10	3/4" NPT	1/2" NPT	28-5/8	17-11/16	11-3/4	80

15-150 PSI water pressure. 40 PSI or above recommended for maximum flow.

*Field gas convertible from natural gas to propane. Conversion kit is included with the heater.

** For propane, minimum inlet gas pressure is 8.0 in W.C. and maximum inlet gas pressure is 13.0 in W.C.

*** Current numbers based on factory testing; 0.4 GPM required for activation; 0.26 GPM required for continuous fire after initial ignition.

Maximum certified or allowable installed altitude is 10,100 for indoor installations and 6,000 feet for outdoor installations.

RESIDENTIAL TANKLESS

PROLINE® XE COMBI BOILER



Meets SCAQMD
Rule 1146.2



Low Level Output



ANSI Z21.13 • CSA 4.9

Indoor Installation Only

Ultra-Low NOx Emissions

- Complies with SCAQMD Rule 1146.2 NOx Emission Requirements Of 14 ng/J or 20 PPM

Modulating burner with 10:1 turndown ratio

- Continuously adjusts the firing rate to match demand for maximum comfort and system efficiency

User Friendly Controls

- Programming the combi boiler takes less than two minutes and uses plain text rather than number codes

Quicker Domestic Hot Water Response

- Advanced control technology prevents the cold water sandwich often found with other combi boilers

Power Direct Vent Design

- Two-pipe sealed combustion system uses outside air, eliminating problems caused by insufficient indoor ventilation

Domestic Hot Water flow rate up to 4.8 gpm at 77°F temperature rise

Maximum Working Pressure

- 50 PSI max pressure (boiler); 150 PSI max pressure (DHW)

Warranty

- 10-year limited warranty on heat exchanger in residential applications
- 5-year warranty on all parts
- Refer to hotwater.com for further warranty details

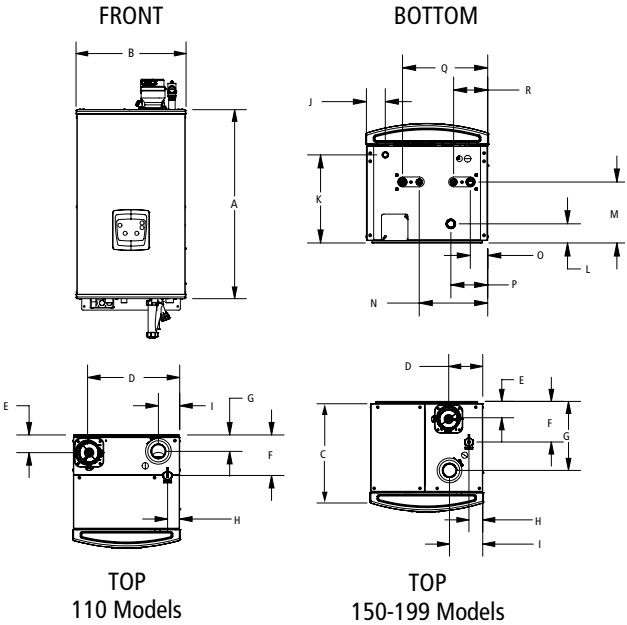

Model Number*	Gas Consumption Input		AFUE%	Heating Capacity BTU/H	Net AHRI Rating BTU/H**
	Minimum BTU/H	Maximum BTU/H			
ACB-110S-N	11,000	110,000	95.0	102,000	89,000
ACB-150S-N	15,000	150,000	95.0	139,000	121,000
ACB-199S-N	19,999	199,999	95.0	185,000	161,000

Minimum in. W.C.†	Maximum in. W.C.	GPM at 77°F Rise	Water Connections		Gas Connection	Approx. Shipping Weight (lbs)
			Space Heating	DHW		
4.0	14.0	2.6	1" NPT	3/4" NPT	1/2" NPT	139
4.0	14.0	3.6	1" NPT	3/4" NPT	1/2" NPT	142
4.0	14.0	4.8	1" NPT	3/4" NPT	1/2" NPT	159

Model Number*	Dimensions		
	A	B	C
ACB-110S-N	32-1/2"	17-1/4"	18"
ACB-150S-N	32-1/2"	18-3/4"	18"
ACB-199S-N	32-1/2"	18-3/4"	18"

*S Models can operate up to 4,500'. For high altitude (3,000' - 9,600'), change S to H. For liquid propane (LP), change N to P.

**The Net AHRI Water Ratings shown are based on a piping and pickup allowance of 1.15. The manufacturer should be consulted before selecting a boiler for installations having unusual piping and pickup requirements, such as intermittent system operation, extensive piping systems, etc.

†For LP, minimum supply pressure is 8.0 in. W.C.

The ratings have been determined under the provisions governing forced draft boilers.

RESIDENTIAL TANKLESS

PROLINE® XE CONDENSING WITH RECIRCULATION PUMP



INDOOR MODEL



OUTDOOR MODEL



ANSI Z21.10.3 • CSA 4.3

Integrated Recirculation Pump

- Simplify installation by eliminating added time and money spent sourcing and installing pump and controls
- Integrated front panel controls are easy to view and set
- 1/2" pipe - 200'
- 3/4" pipe - 500'

Pump Controls

- Included with heater
- Two timer settings
- Adjustable differential settings

ENERGY STAR® Qualified

Ultra-Low NOx Emissions

- Complies with SCAQMD Rule 1146.2 and other air quality management districts with similar requirements for Ultra-Low NOx emissions requirements of 14 ng/J or 20 PPM

Indoor Models

- Include integrated temperature and pump controls with advanced diagnostics that simplify installation and troubleshooting
- Factory-installed power cord

Outdoor Models

- Includes a wall mount temperature remote controller and advanced diagnostics to simplify troubleshooting

Common Vent Indoor Models Up to 8 Heaters

- Easy-link with up to three 540H condensing tankless heaters to increase flow capacity

Safety Features

- Air-Fuel Ratio (AFR) Sensor
- Exhaust & Water Temperature Safety Control
- Overheat Cut-Off Fuse

Internal Freeze Protection

Warranty

- 15-year limited warranty on heat exchanger in residential applications
- 5-year limited warranty on heat exchanger in commercial applications
- 5-year warranty on all parts

INDOOR MODEL

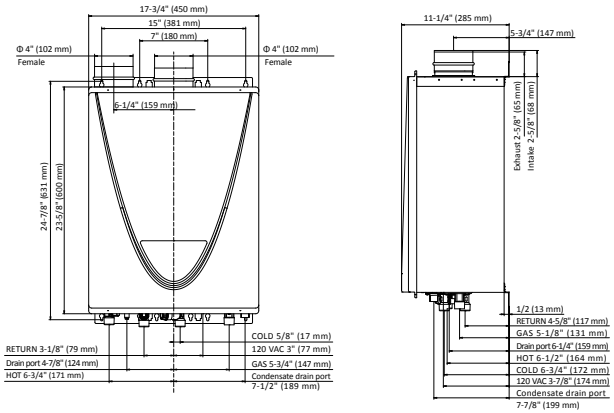

OUTDOOR MODEL

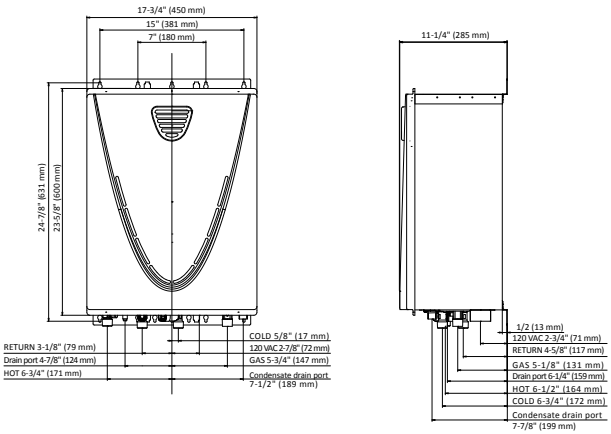

Model Number*	Type	Gas Consumption Input		Inlet Gas Pressure***	
		Minimum** (BTU/H)	Maximum (BTU/H)	Minimum (in. W.C.)	Maximum (in. W.C.)
ATI-540P-N	Natural	15,000	199,000	4.0	10.5

Model Number*	Indoor Model UEF	Outdoor Model UEF	Connections		Sizing Chart (Number of Showers)	
			Water	Gas	Cold Climate†	Warm Climate‡
ATI-540P-N	0.93	0.95	3/4" NPT	3/4" NPT	3	4.5

Model Number*	Clearances (in.)				Approx Shipping Weight (lbs)
	Top	Bottom	Side	Front	
ATI-540P-N	12	12	3	4	71

* For outdoor models, change "ATI" to "ATO". For propane models, change "N" to "P"
 ** For propane models, minimum is 13,000
 *** For propane models, minimum inlet gas pressure is 8.0 in. W.C. and maximum inlet gas pressure is 14.0 in. W.C.
 † Cold climate represents 70°F temperature rise
 ‡ Warm climate represents 50°F temperature rise

RESIDENTIAL TANKLESS

PROLINE® XE CONDENSING HIGH EFFICIENCY



INDOOR MODEL



OUTDOOR MODEL



ANSI Z21.10.3 CSA 4.3

ENERGY STAR® Qualified

Condensing Technology Provides Up to 0.91 UEF

Ultra-Low NOx Emissions

- Complies with SCAQMD Rule 1146.2 and other air quality management districts with similar requirements for Ultra-Low NOx emissions requirements of 14 ng/J or 20 PPM

Copper Primary Heat Exchanger

- 25x better heat transfer than stainless steel thus stabilizing outgoing water temperature quicker and reducing pressure drop across the heat exchanger

Secondary Heat Exchanger

- Marine-Grade 316L stainless steel to protect against corrosion

Indoor Models

- Include a built-in temperature controller and advanced diagnostics to simplify troubleshooting
- Include factory-installed power cords

Outdoor Models

- Include a wall mount temperature remote controller and advanced diagnostics to simplify troubleshooting

Electronic Ignition - No Pilot Light

Safety Features:

- Air-Fuel Ratio (AFR) Sensor
- Exhaust & Water Temperature Safety Control
- Overheat Cut-Off Fuse

Internal Freeze Protection System

Power Vent or Power Direct Vent Design

Warranty

- 15-year limited warranty on heat exchanger in residential applications
- 5-year limited warranty on heat exchanger in commercial applications
- 5-year limited warranty on all parts

INDOOR MODEL

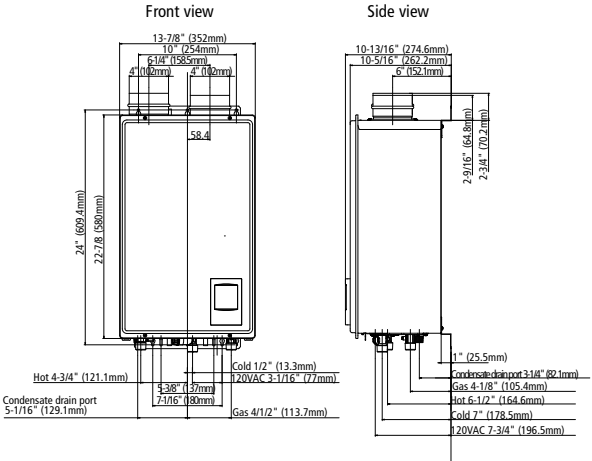

OUTDOOR MODEL

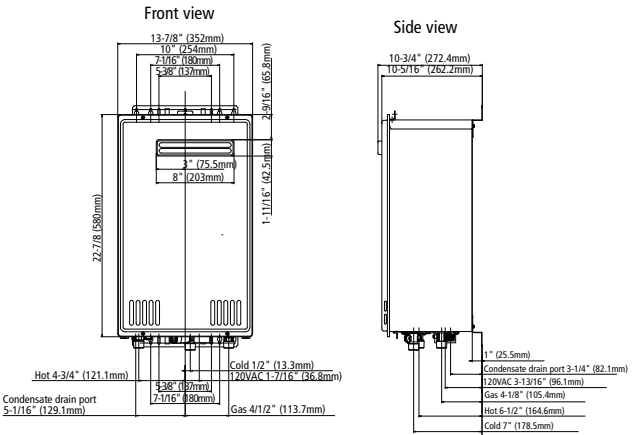

Model Number*	Type	Gas Consumption Input		Inlet Gas Pressure***	
		Minimum** (BTU/H)	Maximum (BTU/H)	Minimum (in. W.C.)	Maximum (in. W.C.)
ATI-140H-N	Natural	15,000	120,000	4.0	10.5

Model Number*	Indoor Model UEF	Outdoor Model UEF	Connections		Sizing Chart (Number of Showers)	
			Water	Gas	Cold Climate†	Warm Climate‡
ATI-140H-N	0.90	0.91	3/4" NPT	1/2" NPT	1.5	2.5

Model Number*	Clearances (in.)				Approx Shipping Weight (lbs)
	Top	Bottom	Side	Front	
ATI-140H-N	12	12	3	4	54

*For outdoor models, change "ATI" to "ATO". For propane models, change "N" to "P"

**For propane models, minimum is 13,000

***For propane models, minimum inlet gas pressure is 8.0 in. W.C. and maximum inlet gas pressure is 14.0 in. W.C.

† Cold climate represents 70°F temperature rise

‡ Warm climate represents 50°F temperature rise

RESIDENTIAL TANKLESS & COMMERCIAL PROLINE® XE CONDENSING HIGH EFFICIENCY



INDOOR MODEL



OUTDOOR MODEL



ANSI Z21.10.3

CSA 4.3

ENERGY STAR® Qualified

Condensing Technology Provides Up to 0.95 UEF

Ultra-Low NOx Emissions

- Complies with SCAQMD Rule 1146.2 and other air quality management districts with similar requirements for Ultra-Low NOx emissions requirements of 14 ng/J or 20 PPM

Maximum Flow Rates up to 10.0 GPM

Heat Exchanger

- Primary heat exchanger of the ATI/ATO-540 is constructed of a commercial-grade copper that is more resilient to erosion
- Copper is 25x better at heat transfer than stainless steel thus stabilizing outgoing water temperature quicker and reducing pressure drop across the heat exchanger
- Secondary heat exchanger is made of marine-grade 316L stainless steel to protect against corrosion

Indoor Models

- Include integrated temperature controls and advanced diagnostics to simplify troubleshooting
- Include factory-installed power cords

Outdoor Models

- Include a wall mount temperature remote controller and advanced diagnostics to simplify troubleshooting

Common Vent Indoor Models up to 8 Units

540H Can Be Used In Both Residential and Commercial Applications

- Easy-link up to 4 heaters
- Multi-link up to 20 heaters

Safety Features

- Air-Fuel Ratio (AFR) Sensor
- Exhaust & Water Temperature Safety Control
- Overheat Cut-off Fuse

Internal Freeze Protection System

Power Vent or Power Direct Vent Design

Warranty

- 15-year limited warranty on heat exchanger in residential applications
- 5-year limited warranty on heat exchanger in commercial applications
- 5-year limited warranty on all parts

INDOOR MODEL

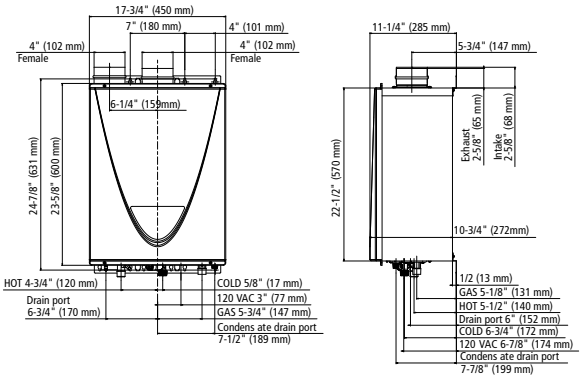

OUTDOOR MODEL

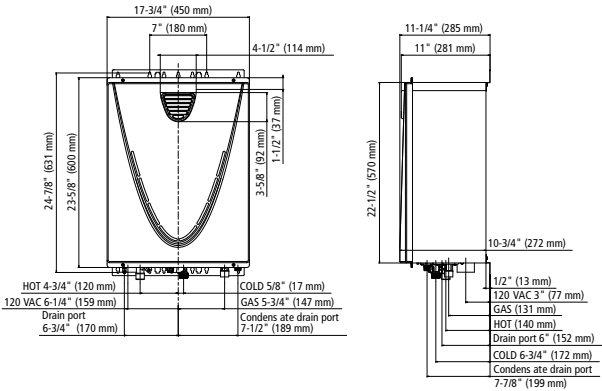

Model Number*	Type	Gas Consumption Input		Inlet Gas Pressure***	
		Minimum** (BTU/H)	Maximum (BTU/H)	Minimum (in. W.C.)	Maximum (in. W.C.)
ATI-240H-N	Natural	15,000	160,000	4.0	10.5
ATI-340H-N	Natural	15,000	180,000	4.0	10.5
ATI-540H-N	Natural	15,000	199,000	4.0	10.5

Model Number*	Indoor Model UEF	Outdoor Model UEF	Connections		Sizing Chart (Number of Showers)	
			Water	Gas	Cold Climate†	Warm Climate‡
ATI-240H-N	0.94	0.95	3/4" NPT	3/4" NPT	2.5	3.5
ATI-340H-N	0.95	0.94	3/4" NPT	3/4" NPT	2.5	4.0
ATI-540H-N	0.93	0.95	3/4" NPT	3/4" NPT	3	4.5

Model Number*	Clearances (in.)				Approx Shipping Weight (lbs)
	Top	Bottom	Side	Front	
ATI-240H-N	12	12	3	4	71
ATI-340H-N	12	12	3	4	71
ATI-540H-N	12	12	3	4	71

*For outdoor models, change "ATI" to "ATO". For propane models, change "N" to "P"

**For propane models, minimum is 13,000

***For propane models, minimum inlet gas pressure is 8.0 in. W.C. and maximum inlet gas pressure is 14.0 in. W.C.

† Cold climate represents 70°F temperature rise

‡ Warm climate represents 50°F temperature rise

RESIDENTIAL TANKLESS

PROLINE® XE

NON-CONDENSING CONCENTRIC VENT



Meets SCAQMD
Rule 1146.2



ANSI Z21.10.3



(510c models only)

Concentric Vent Design

- Power direct vent
- Vertical or horizontal venting up to 43'

Field Convertible from Natural Gas to Propane

Ultra-Low NOx Emissions

- Complies with SCAQMD Rule 1146.2 and other air quality management districts with similar requirements for Ultra-Low NOx emissions requirements of 14 ng/J or 20 PPM

Maximum Flow Rates up to 10.0 GPM

Primary Heat Exchanger

- Primary heat exchanger of the ATI-510C is constructed of a commercial-grade copper that is more resilient to erosion
- Copper is 25x better at heat transfer than stainless steel thus stabilizing outgoing water temperatures quicker and reducing pressure drop across the heat exchanger

Indoor Models Only

- Include integrated temperature controls and advanced diagnostics to simplify troubleshooting
- Include factory-installed power cords

ATI-510C Can be Used in Both Residential and Commercial Applications

- Easy-Link up to 4 units
- Multi-Link up to 20 units

Safety Features

- Air-Fuel Ratio (AFR) Sensor
- Exhaust & Water Temperature Safety Control
- Overheat Cut-Off Fuse

Internal Freeze Protection

Warranty

- 15-year limited warranty on heat exchanger in residential applications
- 5-year limited warranty on heat exchanger in commercial applications
- 5-year limited warranty on all parts

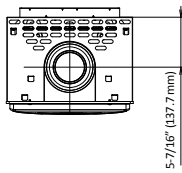

Top view

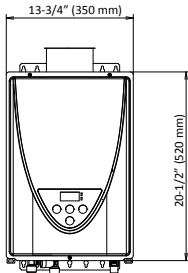

Front view

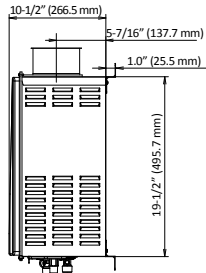

Side view

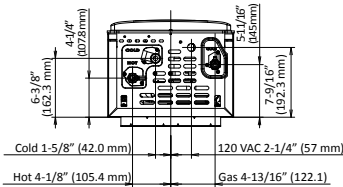

Bottom view

Model Number*	Gas Consumption Input		Inlet Gas Pressure**	
	Minimum (BTU/H)	Maximum (BTU/H)	Minimum (in. W.C.)	Maximum (in. W.C.)
ATI-110C-N	15,000	140,000	4.0	10.5
ATI-310C-N	15,000	190,000	4.0	10.5
ATI-510C-N	15,000	199,000	4.0	10.5

Model Number*	UEF	Connections		Sizing Chart (Number of Showers)	
		Water	Gas	Cold Climate†	Warm Climate‡
ATI-110C-N	0.81	3/4" NPT	3/4" NPT	1.5	2.5
ATI-310C-N	0.81	3/4" NPT	3/4" NPT	2.5	3.5
ATI-510C-N	0.81	3/4" NPT	3/4" NPT	2.5	3.5

Model Number*	Clearances (in.)				Approx Shipping Weight (lbs)
	Top	Bottom	Side	Front	
ATI-110C-N	12	12	3	4	55
ATI-310C-N	12	12	3	4	55
ATI-510C-N	12	12	3	4	55

*Indoor models only. Units are field convertible from natural gas to propane with supplied conversion kit.

**When converted for propane, minimum inlet gas pressure is 8.0 in. W.C. and maximum inlet gas pressure is 14.0 in. W.C.

† Cold climate represents 70°F temperature rise

‡ Warm climate represents 50°F temperature rise

RESIDENTIAL TANKLESS & COMMERCIAL PROLINE® XE NON-CONDENSING ULTRA-LOW NOx



INDOOR MODEL



OUTDOOR MODEL



ANSI Z21.10.3

Ultra-Low NOx Emissions

- Complies with SCAQMD Rule 1146.2 and other air quality management districts with similar requirements for Ultra-Low NOx emissions requirements of 14 ng/J or 20 PPM

Field Convertible from Natural Gas to Propane

Maximum Flow Rates Up To 10.0 GPM

Copper Primary Heat Exchanger

- Primary heat exchange of the ATI/ATO-510U is constructed of a commercial-grade copper that is more resilient to erosion
- Copper is 25x better at heat transfer than stainless steel thus stabilizing outgoing water temperatures quicker and reducing pressure drop across the heat exchanger indoor and outdoor models available

Indoor Models

- Include integrated temperature controls and advanced diagnostics to simplify troubleshooting
- Include factory-installed power cords

Outdoor Models

- Include a wall mount temperature remote controller and advanced diagnostics to simplify troubleshooting

ATI-510U / ATO-510U Can be Used in Both Residential and Commercial Applications

- Easy-Link Up To 4 Units
- Multi-Link Up to 20 Units

Safety Features

- Air-Fuel Ratio (AFR) Sensor
- Exhaust & Water Temperature Safety Control
- Overheat Cut-Off Fuse

Internal Freeze Protection

Power Vent or Power Direct Vent Design

Warranty

- 15-year limited warranty on heat exchanger in residential applications
- 5-year limited warranty on heat exchanger in commercial applications
- 5-year limited warranty on all parts

INDOOR MODEL

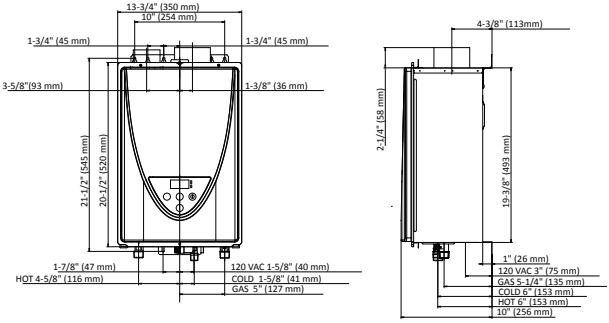

OUTDOOR MODEL

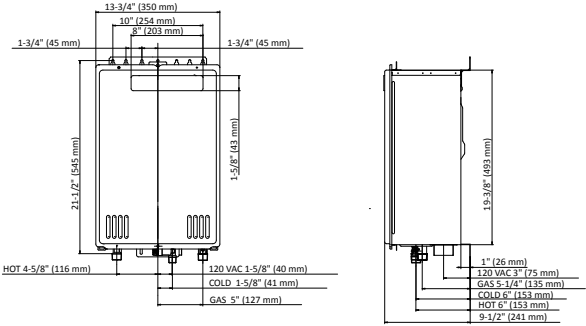

Model Number*	Type	Gas Consumption Input		Inlet Gas Pressure**	
		Minimum (BTU/H)	Maximum (BTU/H)	Minimum (in. W.C.)	Maximum (in. W.C.)
ATI-110U-200	Natural	15,000	140,000	4.0	10.5
ATI-310U-200	Natural	15,000	190,000	4.0	10.5
ATI-510U-200	Natural	15,000	199,000	4.0	10.5

Model Number*	Indoor Model UEF	Outdoor Model UEF	Connections		Sizing Chart (Number of Showers)	
			Water	Gas	Cold Climate†	Warm Climate‡
ATI-110U-200	0.81	0.81	3/4" NPT	3/4" NPT	1.5	2.5
ATI-310U-200	0.81	0.82	3/4" NPT	3/4" NPT	2.5	3.5
ATI-510U-200	0.81	0.81	3/4" NPT	3/4" NPT	2.5	3.5

Model Number*	Clearances (in.)				Approx Shipping Weight (lbs)
	Top	Bottom	Side	Front	
ATI-110U-200	12	12	3	4	39
ATI-310U-200	12	12	3	4	39
ATI-510U-200	12	12	3	4	40

*For outdoor models, change "ATI" to "ATO". Units are field convertible from natural gas to propane with supplied conversion kit.

**When converted for propane, minimum inlet gas pressure is 8.0 in. W.C. and maximum inlet gas pressure is 14.0 in. W.C.

† Cold climate represents 70°F temperature rise

‡ Warm climate represents 50°F temperature rise

COMMERCIAL TANKLESS NON-CONDENSING HEAVY-DUTY



Commercial-Grade Copper Heat Exchanger (Non-ASME Models)

ASME Models Available

5" Category III Stainless Steel Venting

Vertical or Horizontal Venting Installation

Power Vent or Convertible to Power Direct Vent

Electronic Ignition

Low NOx Emissions

Combined Indoor/Outdoor Models

Easy-Link up to 4 Units

Multi-Link up to 10 Units

Warranty

- 6-year limited warranty on heat exchanger
- 5-year limited warranty on all parts



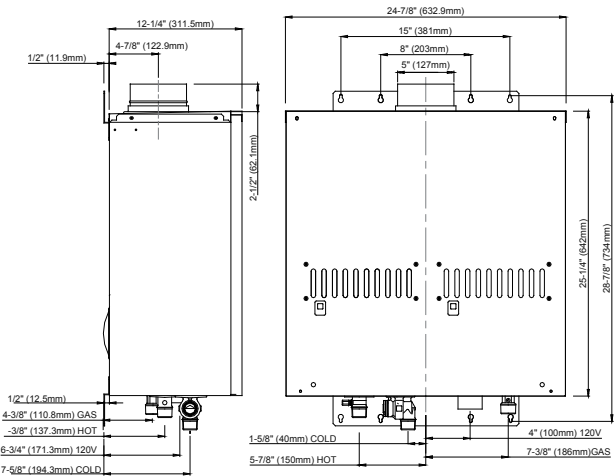

Model Number*	Type	Gas Consumption Input		Inlet Gas Pressure**	
		Minimum (BTU/H)	Maximum (BTU/H)	Minimum (in. W.C.)	Maximum (in. W.C.)
ATIO-910-N	Natural	15,000	380,000	5.0	10.5
ATIO-910-AN	Natural	15,000	380,000	5.0	10.5

Model Number*	Thermal Efficiency	Connections		Sizing Chart (Number of Showers)	
		Water	Gas	Cold Climate†	Warm Climate‡
ATIO-910-N	80%	1" NPT	1" NPT	5	7
ATIO-910-AN	80%	1" NPT	1" NPT	5	7

Model Number*	Clearances (in.)				Approx Shipping Weight (lbs)
	Top	Bottom	Side	Front	
ATIO-910-N	12	12	2	24	113
ATIO-910-AN	12	12	2	24	113

*"-AN" means ASME rated. For propane models, change "N" to "P".

**For propane models, minimum inlet gas pressure is 8.0 in. W.C. and maximum inlet gas pressure is 14.0 in. W.C.

† Cold climate represents 70°F temperature rise

‡ Warm climate represents 50°F temperature rise

COMMERCIAL TANKLESS RACK SYSTEM



Wall Mount



Freestanding



Back-to-Back

Multiple Design and Installation Configurations

- Wall mount, freestanding in-line, and freestanding back-to-back designs
- Indoor and outdoor rack designs
- Uses the CT-199 high efficiency condensing tankless heaters.

Expandable

- Up to 1,194,000 BTU on a single rack system
- Able to link up to 20 heaters together with Multi-Link system

Redundancy

- Multiple combustion systems provide piece of mind
- Easily isolate a unit for maintenance which extends the life of the heaters

Lightweight

- Anodized aluminum frame
- Utilizes the industry's lightest 199,000 BTU high efficiency condensing tankless heater

Easy Field Installation

- Reduce installation costs with three simple connections (cold water, hot water, and gas)

Ultra-Low NOx Emissions

- Complies with SCAQMD Rule 1146.2 and other air quality management districts with similar requirements for Ultra-Low NOx emissions requirements of 14 ng/J or 20 PPM.

Warranty

- 6-year limited warranty on heat exchanger
- 5-year limited warranty on tankless parts
- 1-year limited warranty on rack parts

Model Number	Number of Heaters	Btuh Input		Max Flow (GPM)		
		Min	Max	@ 50°F Rise	@ 70°F Rise	@ 100°F Rise
Wall Mount						
ACI-CRS-22WM-N	2	15,000	398,000	15.2	10.8	7.6
ACI-CRS-22WM-P	2	13,000	398,000	15.2	10.8	7.6
ACI-CRS-23WM-N	2	15,000	398,000	15.2	10.8	7.6
ACI-CRS-23WM-P	2	13,000	398,000	15.2	10.8	7.6
ACI-CRS-33WM-N	3	15,000	597,000	22.8	16.2	11.4
ACI-CRS-33WM-P	3	13,000	597,000	22.8	16.2	11.4
Freestanding						
ACI-CRS-24IL-N	2	15,000	398,000	15.2	10.8	7.6
ACI-CRS-24IL-P	2	13,000	398,000	15.2	10.8	7.6
ACI-CRS-26IL-N	2	15,000	398,000	15.2	10.8	7.6
ACI-CRS-26IL-P	2	13,000	398,000	15.2	10.8	7.6
ACI-CRS-36IL-N	3	15,000	597,000	22.8	16.2	11.4
ACI-CRS-36IL-P	3	13,000	597,000	22.8	16.2	11.4
Back-to-Back						
ACI-CRS-24B2B-N	2	15,000	398,000	15.2	10.8	7.6
ACI-CRS-24B2B-P	2	13,000	398,000	15.2	10.8	7.6
ACI-CRS-34B2B-N	3	15,000	597,000	22.8	16.2	11.4
ACI-CRS-34B2B-P	3	13,000	597,000	22.8	16.2	11.4
ACI-CRS-36B2B-N	3	15,000	597,000	22.8	16.2	11.4
ACI-CRS-36B2B-P	3	13,000	597,000	22.8	16.2	11.4
ACI-CRS-44B2B-N	4	15,000	796,000	30.4	21.6	15.2
ACI-CRS-44B2B-P	4	13,000	796,000	30.4	21.6	15.2
ACI-CRS-46B2B-N	4	15,000	796,000	30.4	21.6	15.2
ACI-CRS-46B2B-P	4	13,000	796,000	30.4	21.6	15.2
ACI-CRS-56B2B-N	5	15,000	995,000	38	27	19
ACI-CRS-56B2B-P	5	13,000	995,000	38	27	19
ACI-CRS-66B2B-N	6	15,000	1,194,000	45.6	32.4	22.8
ACI-CRS-66B2B-P	6	13,000	1,194,000	45.6	32.4	22.8

*For outdoor models, change ATI to ATO

**For Propane, change -N to -P

COMMERCIAL TANKLESS RACK SYSTEM (CONTINUED)

Wall Mount

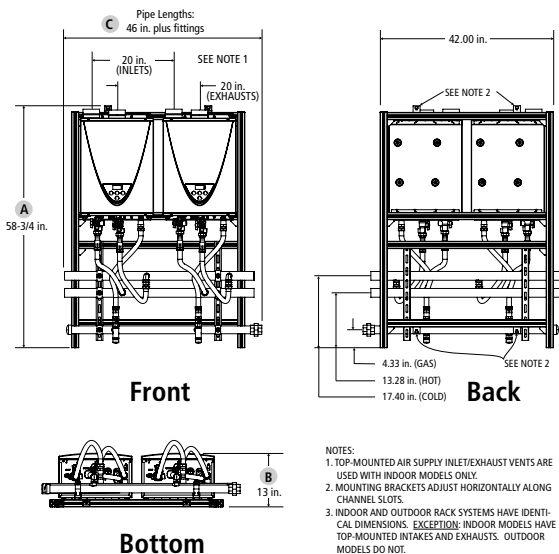

Freestanding

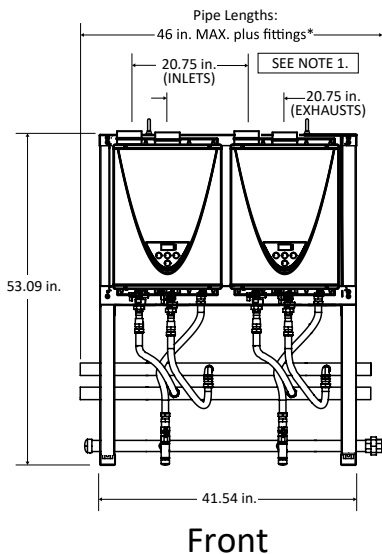

*Fittings to be field supplied.

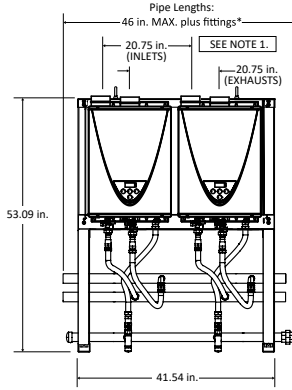

*Fittings to be field supplied.

Front

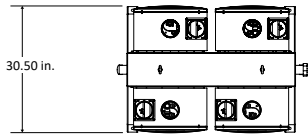

Top

NOTES:

1. TOP-MOUNTED AIR SUPPLY INLET/EXHAUST VENT ARE USED WITH INDOOR MODELS ONLY.
2. INDOOR AND OUTDOOR RACK SYSTEMS HAVE IDENTICAL DIMENSIONS. **EXCEPTION:** INDOOR MODELS HAVE TOP-MOUNTED INTAKES AND EXHAUSTS. OUTDOOR MODELS DO NOT.

Model Number	Dimensions (in)			Approx Shipping Weight (lbs)
	A Length	B Width	C Height	
Wall Mount				
ACI-CRS-22WM-N	46	13.02	57	240
ACI-CRS-22WM-P	46	13.02	57	240
ACI-CRS-23WM-N	66	13.02	57	250
ACI-CRS-23WM-P	66	13.02	57	250
ACI-CRS-33WM-N	66	13.02	57	350
ACI-CRS-33WM-P	66	13.02	57	350
Freestanding				
ACI-CRS-24IL-N	46	20	53.09	330
ACI-CRS-24IL-P	46	20	53.09	330
ACI-CRS-26IL-N	66	20	53.09	396
ACI-CRS-26IL-P	66	20	53.09	396
ACI-CRS-36IL-N	66	20	53.09	448
ACI-CRS-36IL-P	66	20	53.09	448
Back-to-Back				
ACI-CRS-24B2B-N	46	30.5	53.09	330
ACI-CRS-24B2B-P	46	30.5	53.09	330
ACI-CRS-34B2B-N	46	30.5	53.09	404
ACI-CRS-34B2B-P	46	30.5	53.09	404
ACI-CRS-36B2B-N	66	30.5	53.09	447
ACI-CRS-36B2B-P	66	30.5	53.09	447
ACI-CRS-44B2B-N	46	30.5	53.09	481
ACI-CRS-44B2B-P	46	30.5	53.09	481
ACI-CRS-46B2B-N	66	30.5	53.09	519
ACI-CRS-46B2B-P	66	30.5	53.09	519
ACI-CRS-56B2B-N	66	30.5	53.09	597
ACI-CRS-56B2B-P	66	30.5	53.09	597
ACI-CRS-66B2B-N	66	30.5	53.09	674
ACI-CRS-66B2B-P	66	30.5	53.09	674

*For outdoor models, change ATI to ATO

**For Propane, change -N to -P

BUILDING MANAGEMENT SYSTEM BACnet & MODBUS INTERFACE

Connect Your A. O. Smith Water Heater to your Building Management System Using the New Millennium Control from ICC (Industrial Control Communications, Inc.)

- Works with Cyclone, DSE/DVE/DHE (Except BTX-80)
- Use the ICC Control to enable/disable the water heater
- Change Temperature Set points and differentials
- Two models with four different configurations to connect to BACnet and Modbus
- Ethernet and Serial RS-485 versions available
- 2 wire or 4 wire RS-485 Network
- Power can be supplied via the USB cable, as a 7-24 VDC input on the main terminal Block, or via IEEE 802.3af Power over Ethernet (PoE on ETH-1000 only)
- Configure protocols, network characteristics, and client/server object definitions
- Graphically interact with the internal database in real-time via USB connection
- Automatically discover and configure IP settings Ethernet gateways connected to the current subnet
- Update Firmware

Building Management System BACnet and Modbus Interface

BMS gateway for control of A. O. Smith Water Heaters

Connect your A. O. Smith water heater to your building management system using the new Millennium control from ICC* (Industrial Control Communications, Inc.)

- Works with Cyclone, BTH, BTHL, BTX-100 and BTXL-100, DHE/DVE, DSE and DVE



ETH-1000 Ethernet connection
Mirius Serial Gateway



Kit Part #	Connection Type
100316044	Serial
100316045	Ethernet (IP)

One unit needed per water heater.

POINT-OF-USE



Dry-Fire Protection

- Prevents element failure due to dry fire
- Internal air bypass
- Temporary shutoff with excess air in chamber

Wide Variety of KW and Voltage Options for Every Application

- 2.4kW – 12kW
- 120V, 208V, 240V, 277V options

Easy Install

- Wall mount in vertical or horizontal position
- 3/4" NPT water connections with two 3/4" x 1/2" reducers included
- No venting required
- No T&P valve required (check local code)

Scale-Reduction Technology

- Reduces failures and service requirements due to hard scale buildup
- Power-sharing technology reduces scale deposits on the element
- Dupont™ Zytel® chambers naturally resist scale buildup

Code Compliance

- Meets current UBC and CEC National Codes
- Listed and tested to UL 499 Appliance and UL 834 Space Heating Standards
- Control tested to achieve temperature limit control requirements of UL 353 and CSA C22.2

5-Year Limited Warranty

- For complete information, consult the written warranty or go to hotwater.com

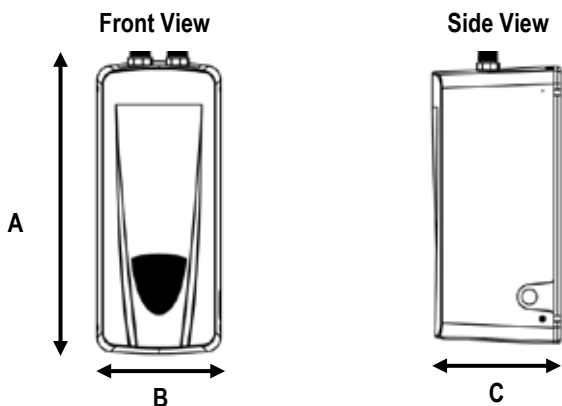

Model Number	Wattage (kW)	Voltage (V)	Amperage (A)	UEF	Dimensions (in)			Approx. Shipping Weight (lbs)
					A	B	C	
RPVA-24K	2.4	120	20	0.6	16-5/8	6-1/2	7-3/16	8
RPVA-30K	3	120	25	0.6	16-5/8	6-1/2	7-3/16	8
RPVA-35K	3.5	120	29	0.6	16-5/8	6-1/2	7-3/16	8
RPVA-35E	3.5	240	15	0.6	16-5/8	6-1/2	7-3/16	8
RPVA-40X	4	208	19	0.6	16-5/8	6-1/2	7-3/16	8
RPVA-45E	4.5	240	19	0.6	16-5/8	6-1/2	7-3/16	8
RPVA-55E	5.5	240	23	0.6	16-5/8	6-1/2	7-3/16	8
RPVA-70E	7	240	29	0.6	16-5/8	6-1/2	7-3/16	8
RPVA-78X	7.8	208	38	0.6	16-5/8	6-1/2	7-3/16	8
RPVA-80E	8	240	33	0.6	16-5/8	6-1/2	7-3/16	8
RPVA-90E	9	240	38	0.6	16-5/8	6-1/2	7-3/16	8
RPVA-120E	12	240	50	0.6	16-5/8	6-1/2	7-3/16	8
CPVA-30Y	3	277	11	0.6	16-5/8	6-1/2	7-3/16	8
CPVA-40Y	4	277	14	0.6	16-5/8	6-1/2	7-3/16	8
CPVA-60Y	6	277	21	0.6	16-5/8	6-1/2	7-3/16	8
CPVA-73Y	7.3	277	26	0.6	16-5/8	6-1/2	7-3/16	8
CPVA-90Y	9	277	32	0.6	16-5/8	6-1/2	7-3/16	8

Dimensions and specifications are subject to change without notice in accordance with our policy of continuous product improvement.

Recommended that all wire be rated 90°C or greater.

Factory set point is 105°F. This can easily be changed in the field as needed or desired.

Temp range is 90°-140°F.

240V models can run on 208V with 25% reduced power output.

* Maximum recommended wire size is #6 cu AWG.

ELECTRIC TANKLESS



RESIDENTIAL



COMMERCIAL



Dry-Fire Protection

- Prevents element failure due to dry fire
- Internal air bypass
- Temporary shutoff with excess air in chamber

Wide Variety of KW and Voltage Options for Every Application

- 12.2kW – 32kW
- 208V and 240V options

Easy Install

- Mounts easily to the wall
- No venting required
- ¾" NPT water connections
- No T&P valve required (check local codes)

Continuous Hot Water When Sized Appropriately

Scale-Reduction Technology

- Reduces failures and service requirements due to hard scale buildup
- Power-sharing technology reduces scale deposits on the element
- Dupont™ Zytel® chambers naturally resist scaling buildup

Soft Start

- Unit will not cause lights to dim with hard electricity draw

Code Compliance

- Meets current UBC and CEC National Codes
- Meets or exceeds current federal minimum energy standards, according to the National Appliance Energy Conservation Act (NAECA)
- Listed and tested to UL 499 Appliance and UL 834 Space Heating standards
- Control tested to achieve temperature limit control requirements of UL 353 and CSA C22.2

5-Year Limited Warranty

- For complete information, consult the written warranty or go to hotwater.com

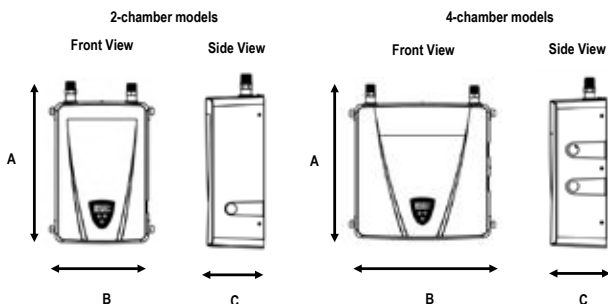

Model Number	Wattage (kW)	Voltage (V)	Amperage (A)	UEF	Dimensions (in)			Approx. Shipping Weight (lbs)
					A	B	C	
Residential 2-Chamber Models								
R2VA-140E	14	240	58	0.84	17-3/4	11-1/2	6-1/8	13
R2VA-140X	14	208	67	0.84	17-3/4	11-1/2	6-1/8	13
R2VA-160E	16	240	67	0.84	17-3/4	11-1/2	6-1/8	13
Residential 4-Chamber Models								
R4LA-180E	18	240	75	0.92	18-1/8	17	6-1/8	20
R4LA-220E	22	240	92	0.92	18-1/8	17	6-1/8	20
R4LA-240E	24	240	100	0.92	18-1/8	17	6-1/8	20
R4LA-280E	28	240	117	0.92	18-1/8	17	6-1/8	20
R4LA-280X	28	208	135	0.92	18-1/8	17	6-1/8	20
R4MA-320E	32	240	133	0.93	18-1/8	17	6-1/8	20

Model Number	Wattage (kW)	Voltage (V)	Amperage (A)	UEF	Dimensions (in)			Approx. Shipping Weight (lbs)
					A	B	C	
Commercial 2-Chamber								
C2VA-120E	12.2	240	51	0.84	17-3/4	11-1/2	6-1/8	13
C2VA-140E	14	240	58	0.84	17-3/4	11-1/2	6-1/8	13
C2VA-140X	14	208	67	0.84	17-3/4	11-1/2	6-1/8	13
C2VA-160E	16	240	67	0.84	17-3/4	11-1/2	6-1/8	13
Commercial 4-Chamber								
C4LA-180E	18	240	75	0.92	18-1/8	17	6-1/8	20
C4LA-220E	22	240	92	0.92	18-1/8	17	6-1/8	20
C4LA-280E	28	240	117	0.92	18-1/8	17	6-1/8	20
C4LA-280X	28	208	135	0.92	18-1/8	17	6-1/8	20
C4MA-320E	32	240	133	0.93	18-1/8	17	6-1/8	20

Dimensions and specifications are subject to change without notice in accordance with our policy of continuous product improvement.

Temperature Range: 90°- 140°F.

Recommended that all wire be rated 90°C or greater.

Factory set point is 120°F. This can easily be changed in the field as needed or desired.

Refer to National Electric Code Article 220 for calculating load contribution.

240V models can run on 208V with 25% reduced power output.

Refer to local code where applicable.

* Maximum recommended wire size is #6 cu AWG.

COMMERCIAL GAS CYCLONE® HE



Power Vent Design for Installation Versatility

- Power vent using PVC, CPVC, ABS or Polypropylene either thru-the-wall or thru-the-roof

Condensing Design

- Helical internal heat exchanger keeps hot combustion gases in the tank longer to extract more heat into the water
- High efficiency operation with 0.88 UEF (94% Thermal Efficiency) which saves money on operating costs compared to a standard efficiency gas water heater

High Output with Small Footprint

- 22" diameter, combined with 90% efficiency, 50-gallon tank and 76,000 BTU input means Cyclone® HE can be installed in less space than a larger 75-gallon unit, with equal or better performance

Side-Mounted Hot and Cold Recirculating Taps

Two Heavy-Duty Anode Rods

3-Year Limited Tank and 1-Year Limited Parts Warranty

- For complete warranty information, consult written warranty or go to hotwater.com



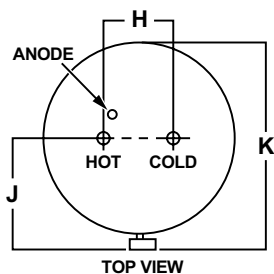

* INSTALL IN ACCORDANCE WITH LOCAL CODES

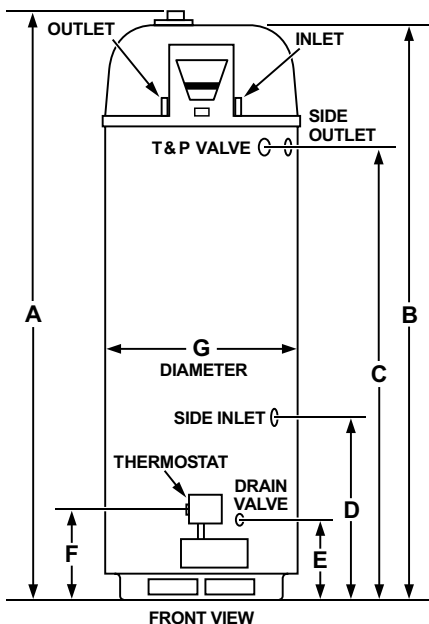

Model Number	Gallon Capacity	Recovery Capacity GPH @ 100°F Rise	BTU Input Per Hour	Approx. Shipping Weight (lbs)
BTX-80	50	83	76,000	225

Model Number	Dimensions in Inches				
	A	B	C	D	E
BTX-80	71	68-5/8	52	21	9-1/8

Model Number	Dimensions in Inches				
	F	G	H	J	K
BTX-80	12	22	8	15-3/4	27

Available in Natural Gas only.
 Standard model certified from sea level to 5,300 ft. elevation. Order SMR S54 for elevations to 10,100 ft.
 Optional Condensate Neutralization Kits available (Part Number 100112380).

COMMERCIAL GAS CYCLONE® Xi



ENERGY STAR® QUALIFIED

Condensing Design

- Helical internal heat exchanger keeps hot combustion gases in the tank longer to extract more heat into the water
- High efficiency operation with up to 0.88 UEF (96% Thermal Efficiency) which saves money on operating costs compared to a standard efficiency gas water heater

Advanced Electronic Control

- Optional Powered Anode available
- Exclusive A. O. Smith designed touch display control system
- Precise temperature control
- Built-in diagnostics and operational information

Power Direct Vent Design

- Power Direct vent using PVC, CPVC or Polypropylene either thru-the-wall or thru-the-roof
- Optional concentric vent and low profile termination kits are available

Ultra-Low NOx

- Complies with SCAQMD Rule 1146.2 and other air quality management districts with similar requirements for Ultra-Low NOx emissions requirements of 14 ng/J or 20 PPM

Side-Mounted Hot and Cold Recirculating Taps

- Hot and cold "side taps" allow Vertex Power Direct Vent to be used for combination space/water heating applications

Code Compliance

- Meets IBC and ICC National Codes
- Meets the thermal efficiency and standby loss requirements of the U. S. Department of Energy and current edition of ASHRAE/IES 90.1

3-Year Limited Tank and Parts Warranty

- For complete information, consult written warranty or go to hotwater.com

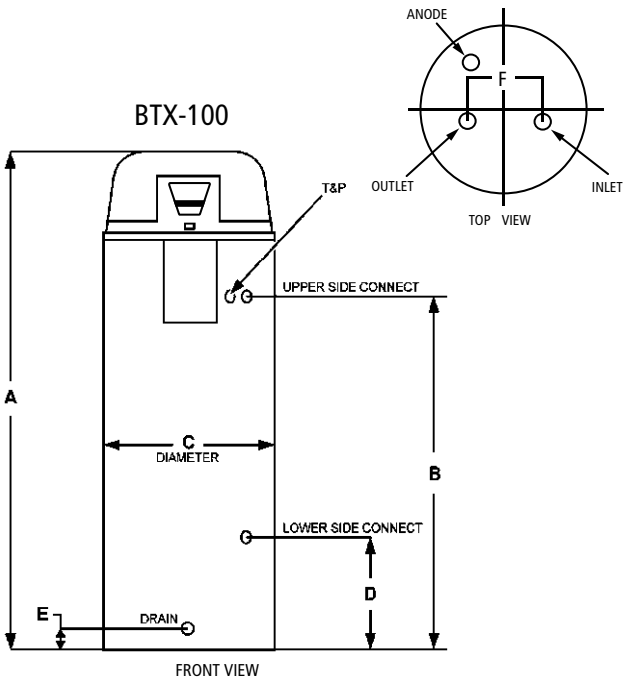

Model Number	Gallon Capacity	Recovery Capacity GPH @ 100°F Rise	BTU Input Per Hour	Approx. Shipping Weight (lbs)
BTX-100	50	116	100,000	255

Model Number	Dimensions in Inches					
	A	B	C	D	E	F
BTX-100	66-3/4	49-1/4	22	15-3/4	3	8

Standard model certified from sea level to 10,100 ft. elevation.
 Available with a Powered Anode. Specify when ordering.
 Optional Concentric Vent Kits (100109357) and Condensate Neutralization Kits (100112380).
 Specify when ordering propane (LP) gas.



ENERGY STAR® QUALIFIED

Condensing Design

- Helical internal heat exchanger keeps hot combustion gases in the tank longer to extract more heat into the water
- High efficiency operation with up to 0.88 UEF (96% Thermal Efficiency) which saves money on operating costs compared to a standard efficiency gas water heater

Advanced Electronic Control

- Optional Powered Anode available
- Exclusive A. O. Smith designed touch display control system
- Precise temperature control
- Built-in diagnostics and operational information

Power Direct Vent Design

- Power Direct vent using PVC, CPVC or Polypropylene either thru-the-wall or thru-the-roof
- Optional concentric vent and low profile termination kits are available

Ultra-Low NOx

- Complies with SCAQMD Rule 1146.2 and other air quality management districts with similar requirements for Ultra-Low NOx emissions requirements of 14 ng/J or 20 PPM

Side-Mounted Hot and Cold Recirculating Taps

- Hot and cold "side taps" allow Vertex Power Direct Vent to be used for combination space/ water heating applications

Code Compliance

- Meets IBC and ICC National Codes
- Meets the thermal efficiency and standby loss requirements of the U. S. Department of Energy and current edition of ASHRAE/IES 90.1

3-Year Limited Tank and Parts Warranty

- For complete information, consult written warranty or go to hotwater.com

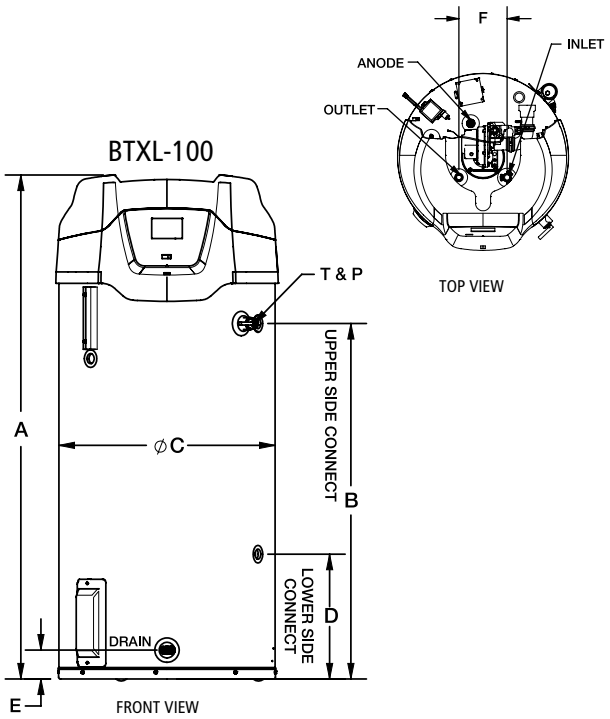

Model Number	Gallon Capacity	Recovery Capacity GPH @ 100°F Rise	BTU Input Per Hour	Approx. Shipping Weight (lbs)
BTXL-100	75	116	100,000	382

Model Number	Dimensions in Inches					
	A	B	C	D	E	F
BTXL-100	65-1/4	45-5/8	27-3/4	16	3-3/4	8

Standard model certified from sea level to 10,100 ft. elevation.
 Available with a Powered Anode. Specify when ordering.
 Optional Concentric Vent Kits (100111100) and Condensate Neutralization Kits (100112380).
 Specify when ordering propane (LP) gas.

COMMERCIAL GAS

CYCLONE® MXi—MODULATING



High Efficiency Modulating Pre-Mix Powered Burner

- Down-fired pre-mix burner provides optimum efficiency and quiet operation
- Top-mounted burner position prevents condensation from affecting burner operation

Up to 98% Efficient

Intelligent Control System with Touch Screen Display

- Exclusive A. O. Smith designed control system
- Provides detailed water heater status information
- Precise temperature control adjustable from 90 to 180 degrees
- Built-in diagnostics
- Run history information
- Cyclone water heaters include iCOMM remote connectivity; models 120-250 require optional Wi-Fi communications kit, models 300-500 come standard with Wi-Fi connectivity
- Convenient iOS and Android Phone App

Submerged Combustion Chamber with Helical Heat Exchanger Coil

- Positioned in center of tank, surrounded by water to virtually eliminate radiant heat loss from chamber
- Direct spark ignition
- Spiral heat exchanger keeps hot burner gases swirling, uses centrifugal force to maximize efficiency of heat transfer to water in tank
- Spiral heat exchanger reduces lime scale from forming on water-side surfaces, which maintains energy efficiency over time

Power Anodes Standard on All Models

- Provides long-lasting tank protection in varying water conditions
- Powered anodes are non-sacrificial
- Automatically adjusts output needed to properly protect the tank

3-Year Limited Tank and 1-Year Limited Parts Warranty

- For complete warranty information, consult written warranty or go to hotwater.com



Model Number	Gallon Capacity	Recovery Capacity	Input BTU/HR
BTH-120(A)	60	138	120,000
BTH-150(A)	100	178	150,000
BTH-199(A)	100	235	199,900
BTH-250(A)	100	291	250,000
BTH-300(A)	119	349	300,000
BTH-400(A)	119	460	399,000
BTH-500(A)	119	576	499,000

Model Number	Approx. Shipping Weight (lbs) Std	Approx. Shipping Weight (lbs) ASME
BTH-120(A)	460	490
BTH-150(A)	523	553
BTH-199(A)	523	553
BTH-250(A)	523	553
BTH-300(A)	855	855
BTH-400(A)	855	855
BTH-500(A)	855	855

Optional Concentric Vent Kits 100111100 (BTH-120 through BTH-250 models).
100113124 (BTH-300 through BTH-500 models).

Electrical characteristics- 120V-60 Hz A.C., 5.0A.

"A" in the model number represents ASME construction.

Models are certified from sea level to 10,100 ft. elevation.

Line drawings and dimensions on the following page.

COMMERCIAL GAS

CYCLONE® MXi—MODULATING

(CONTINUED)

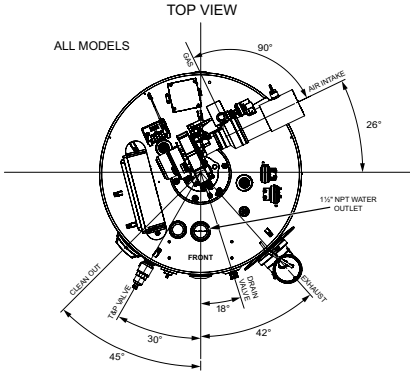
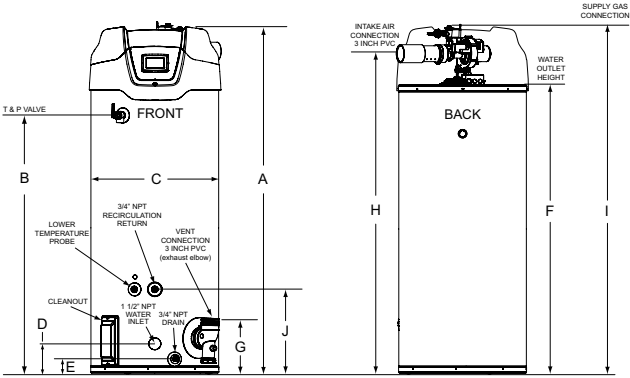

* Center line of water outlet on top of the water heaters is approximately 7 inches from the front edge of the water heater

Model Number	Dimensions in Inches				
	A	B	C	D	E
BTH-120(A)	3	27.75	6.3	35	53.5
BTH-150(A)	3	27.75	6.3	56.38	75.75
BTH-199(A)	3	27.75	6.3	56.38	75.75
BTH-250(A)	3	27.75	6.3	56.38	75.75

Model Number	Dimensions in Inches				
	F	G	H	I	J
BTH-120(A)	55.5	11.25	42.25	48.5	18.25
BTH-150(A)	76	11.25	64	70	18.25
BTH-199(A)	76	11.25	64	70	18.25
BTH-250(A)	76	11.25	64	70	18.25

Optional Concentric Vent kit 100113124 (BTH-300 through BTH-500 models).

Electrical characteristics- 120V-60 Hz A.C., 5.0A.

"A" in the model number represents ASME construction.

Models are certified from sea level to 10,100 ft. elevation.

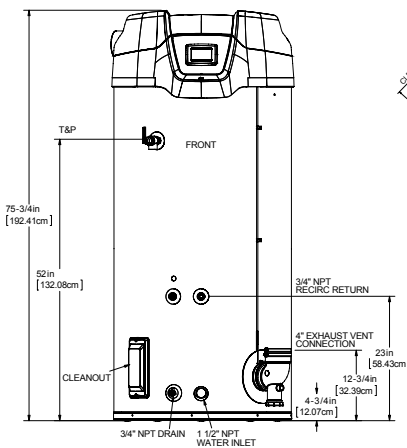
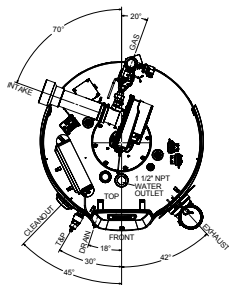
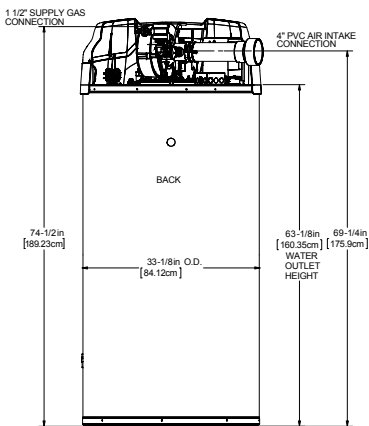

Model Number	Dimensions in Inches				
	A	B	C	D	E
BTH-300(A)	4.75	33.12	4.75	52	75.75
BTH-400(A)	4.75	33.12	4.75	52	75.75
BTH-500(A)	4.75	33.12	4.75	52	75.75

Model Number	Dimensions in Inches				
	F	G	H	I	J
BTH-300(A)	73.75	12.75	63.13	69.25	23
BTH-400(A)	73.75	12.75	63.13	69.25	23
BTH-500(A)	73.75	12.75	63.13	69.25	23

Optional Concentric Vent kit 100113124 (BTH-300 through BTH-500 models).

Electrical characteristics- 120V-60 Hz A.C., 5.0A.

"A" in the model number represents ASME construction.

Models are certified from sea level to 10,100 ft. elevation.

COMMERCIAL GAS

CYCLONE® LV (LARGE VOLUME)



ASME



(All models except BTHL-500)

Large Volume Tank + Condensing Design

- Large volume, integrated storage capacity to 250-gallons eliminates need for multiple water heaters or separate storage tank, saving space and install cost
- Helical internal heat exchanger keeps hot combustion gases in the tank longer to extract more heat into the water
- Models from 150,000 to 500,000 Btu/h deliver thermal efficiencies to 96%, saving money on operating costs
- PermaGlas® glass-lining process provides superior protection against corrosion for the large volume, ASME-certified storage tank

Electronic Control & Display

- iCOMM™ connectivity platform provides diagnostic and operational information
- Integrated color touch display/control system is standard on all models
- Precise temperature control, adjustable from 90° F. to 180° F
- Remote monitoring, diagnostic fault notifications, and control of the set point and differential via the free A. O. Smith mobile app

Submerged Combustion Chamber with Helical Heat Exchanger Coil

- Positioned in center of tank, surrounded by water to virtually eliminate radiant heat loss from chamber
- Direct spark ignition
- Spiral heat exchanger keeps hot burner gases swirling, uses centrifugal force to maximize efficiency of heat transfer to water in tank
- Spiral heat exchanger reduces lime scale from forming on water-side surfaces, which maintains energy efficiency over time

Power Anodes Standard on All Models

- Provides long-lasting tank protection in varying water conditions
- Powered anodes are non-sacrificial
- Automatically adjusts output needed to properly protect the tank

5-Year Limited Tank and 1-year Limited Parts Warranty

- For complete warranty information, consult written warranty or go to hotwater.com

Model Number	Gallon Capacity	Recovery Capacity	Input BTU/HR	Approx. Shipping Weight (lbs) ASME
BTHL-150A	250	175	150,000	1125
BTHL-199A	250	230	199,900	1125
BTHL-250A	250	285	250,000	1125
BTHL-300A	220	342	300,000	1420
BTHL-400A	220	451	399,900	1420
BTHL-500A	220	557	499,900	1420

"A" in model number represents ASME construction.
Models are certified from sea level to 10,100 ft. elevation.

Line drawings and dimensions on the following page.

COMMERCIAL GAS CYCLONE® LV (LARGE VOLUME)

BTHL 150A-250A

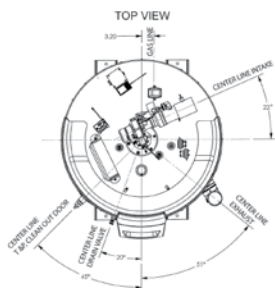
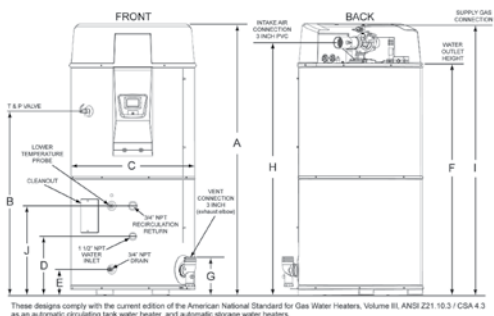

* Center line of water outlet on top of the water heaters is approximately 13 inches from the front edge of the water heater.

Figure 5. Rough-In Dimensions

Model Number	Dimensions				
	A	B	C	D	E
BTHL-150A	91-1/2	62-5/8	42-1/8	20-1/2	8-1/2
BTHL-199A	91-1/2	62-5/8	42-1/8	20-1/2	8-1/2
BTHL-250A	91-1/2	62-5/8	42-1/8	20-1/2	8-1/2

Model Number	Dimensions				
	F	G	H	I	J
BTHL-150A	78-1/8	12	85	90-1/8	30-1/2
BTHL-199A	78-1/8	12	85	90-1/8	30-1/2
BTHL-250A	78-1/8	12	85	90-1/8	30-1/2

Optional Concentric Vent Kits available. 100111100 (BTHL-150A through BTHL-250A models).

Optional Condensate Neutralization Kits available. 100112380 (BTHL-150A through BTHL-199A models), 100112381 (BTHL-250A through BTHL-500A models).

Electrical characteristics - 120V-60 Hz A.C., 5.0A

"A" in model number represents ASME construction.

Models are certified from sea level to 10,100 ft. elevation.

BTHL 300A-500A

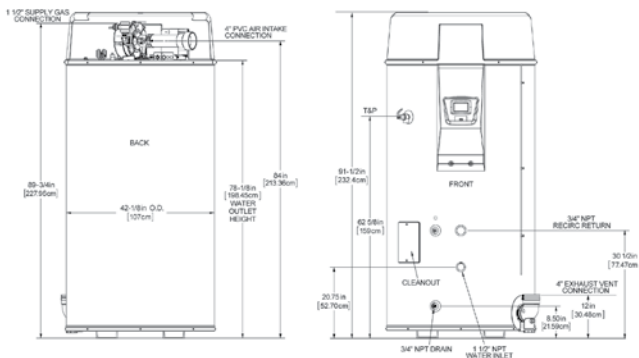

TOP VIEW

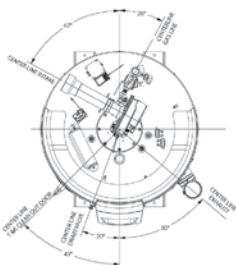

Model Number	Dimensions				
	A	B	C	D	E
BTHL-300A	91-1/2	62-5/8	42-1/8	20-3/4	8-1/2
BTHL-400A	91-1/2	62-5/8	42-1/8	20-3/4	8-1/2
BTHL-500A	91-1/2	62-5/8	42-1/8	20-3/4	8-1/2

Model Number	Dimensions				
	F	G	H	I	J
BTHL-300A	78-1/8	12	84	89-3/4	30-1/2
BTHL-400A	78-1/8	12	84	89-3/4	30-1/2
BTHL-500A	78-1/8	12	84	89-3/4	30-1/2

Optional Concentric Vent Kits available. 100113124 (BTHL-300A through BTHL-500A models).

Optional Condensate Neutralization Kits available. 100112381 (BTHL-250A through BTHL-500A models).

Electrical characteristics - 120V-60 Hz A.C., 5.0A

"A" in model number represents ASME construction.

Models are certified from sea level to 10,100 ft. elevation.

COMMERCIAL GAS

POLARIS® HIGH EFFICIENCY



ENERGY STAR® QUALIFIED

Stainless Steel Construction

- Tank and helical heat exchanger are constructed from 444 stainless steel for excellent corrosion resistance without the need for an anode

Condensing Design

- Helical internal heat exchanger keeps hot combustion gases in the tank longer to extract more heat into the water
- High efficiency operation with up to 0.90 UEF (96% Thermal Efficiency) which saves money on operating costs compared to a standard efficiency gas water heater

Power Direct Vent Design

- Direct vent using PVC, CPVC or ABS either thru-the-wall or thru-the-roof
- Optional concentric vent kit

Whisper Quiet Operation

- Ultra quiet blower and burner minimize noise

Advanced Electronic Control

- Exclusive A. O. Smith designed touch display control system
- Precise temperature control
- Built-in diagnostics and operational information

Ultra-Low NOx

- Complies with SCAQMD Rule 1146.2 and other air quality management districts with similar requirements for Ultra-Low NOx emissions requirements of 14 ng/J or 20 PPM

Code Compliance

- Meets IBC and ICC National Codes
- Meets the thermal efficiency and standby loss requirements of the U. S. Department of Energy and current edition of ASHRAE/IES 90.1

10-Year Limited Tank and 1-Year Parts Warranty

- For complete information, consult written warranty or go to hotwater.com



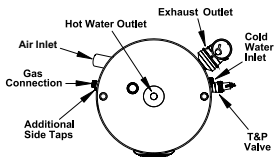

TOP

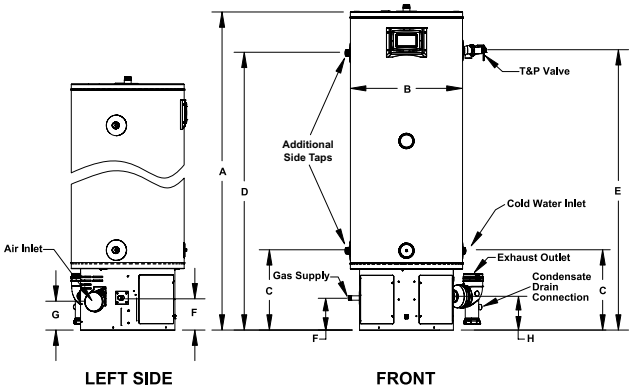

LEFT SIDE

FRONT

Model Number	Gallon Capacity	BTU/h Input Gallon Per Hour	Thermal Efficiency	Recovery @ 100° Rise Gallon Per Hour	Dimensions in Inches	
					A	B
BSS 130	34	130,000	96%	149	48-1/2	22
BSS 150	34	150,000	94%	171	48-1/2	22
BTS 130	50	130,000	95%	149	62-3/8	22
BTS 150	50	150,000	95%	171	63-3/4	22
BTS 175	50	175,000	96%	200	63-3/4	22
BTS 199	50	199,000	96%	227	63-3/4	22

Model Number	Vent Connection	1" Water Connections		T&P	Gas Supply*	Approx. Shipping Weight (lbs)
		C	D	E	F	
BSS 130	2 or 3	15-3/4	40-1/2	41	6-3/8	150
BSS 150	2 or 3	15-3/4	40-1/2	41	6-3/8	150
BTS 130	2 or 3	15-3/4	54-1/2	55	6-3/8	176
BTS 150	2 or 3	15-3/4	55-3/4	56-1/4	6-3/8	180
BTS 175	3	15-3/4	55-3/4	56-1/4	6-3/8	180
BTS 199	3	15-3/4	55-3/4	56-1/4	6-3/8	180

Available in Propane (LP) gas. Specify when ordering Propane (LP) gas.
Models certified for sea level to 7,700 ft. elevation.

TX1 INTEGRATED TANKLESS ON TANK



Delivers 96% Thermal Efficiency Ultra-Low NOx Operation

- Complies with SCAQMD Rule 1146.2 and other Air Quality Management Districts with similar requirements for ultra low-NOx emissions

Uses CT-199 Commercial Tankless

- Modulating burner
- Primary heat exchanger constructed of commercial grade copper
- Secondary heat exchanger constructed of 316 grade stainless steel
- Advanced electronic control with integrated diagnostics
- 185°F maximum temperature

119 Gallon Storage Tank

- 4.1 GPM pump
- Glass lined tank
- Multiple anodes to protect the tank
- Front water inlet and top water outlet

6 Year Limited Heat Exchanger and Tank, 5 Year Limited Parts Warranty

- For complete information, consult written warranty or go to hotwater.com



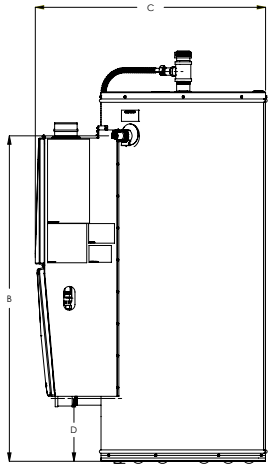
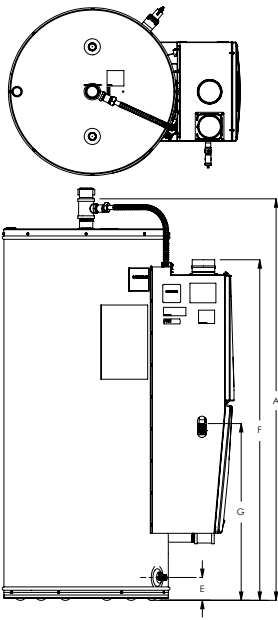

Model Number	Gallon Capacity	Input BTU/HR	Thermal Efficiency %	Recovery @ 100° Rise GPH	Approx. Shipping Weight (lbs.)
ATX-199	119	199,000	96	232	520

Model Number	Dimensions						
	A	B	C	D	E	F	G
ATX-199	72	58-11/16	41	11-13/16	4-5/16	61-3/8	30

Electrical characteristics-120V-60Hz A.C., 5.0 A

Propane gas models available

Dimensions and specifications subject to change without notice in accordance with our policy of continuous product improvement

COMMERCIAL GAS

MASTER-FIT® BTR



The Eliminator™ Self-Cleaning System

- Designed to significantly reduce or eliminate sediment build-up inside the tank
- Reduced sediment build-up maintains rated thermal efficiency and reduces water heating costs
- Self-cleaning system maximizes tank life

Factory-Installed Draft Diverter and Automatic Flue Damper (BTR-120-400 Models)

- BTR-500 Model features induced draft design and no damper
- Low-profile draft diverter helps for installation in tight spaces
- Automatic motorized flue damper helps minimize standby heat loss

Three Water Connection Options for Added Flexibility

- Hot and cold water connections can be made through front, top or rear of unit
- Eliminator™ system operates when cold water is connected through front

3-Year Limited Tank and 1-Year Warranty

- For complete warranty information, consult written warranty or go to hotwater.com



Model Number	Gallon Capacity	Input BTU/HR Natural Gas	Recovery Capacity GPH @ 100°F Rise
BTR-120*	71	120,000	116
BTR-154	81	154,000	149
BTR-180	81	180,000	175
BTR-197	100	199,000	193
BTR-199	81	199,000	193
BTR-200 (A)	100	199,000	193
BTR-250* (A)	100	250,000	242
BTR-251* (A)	65	251,000	243
BTR-275* (A)	100	275,000	267
BTR-305 (A)	65	305,000	296
BTR-365 (A)	85	365,000	354
BTR-400 (A)	100	390,000	378
BTR-500 (A)	85	500,000	485

Specify when ordering propane (LP) gas.

*Model BTR 120 is shipped with 6" x 5" flue outlet adapter. Models BTR 250, 251 and 275 are shipped with a 8" x 6" flue outlet adapter.

Standard models certified from sea level to 2,000 ft. elevation. Order SMR S54 for elevations up to 8,000 ft.

BTR-500 model features induced draft design and no damper.

Line drawings and dimensions on the following page.

Master-Fit BTR 120-400

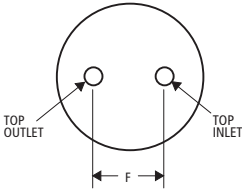
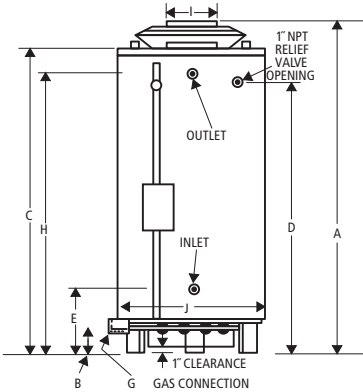

MODEL BTR-120-400

Master-Fit BTR 500

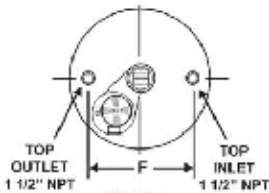
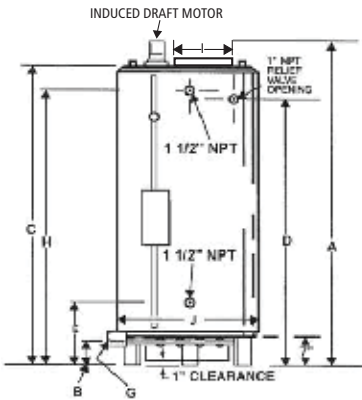

MODEL BTR-500

Model Number	Dimensions in Inches					
	A	B	C	D	E	F
BTR-120*	69-3/4	4-1/4	59-1/2	50-7/8	19-11/16	19
BTR-154	67-1/2	4-1/2	62	53-5/8	20-1/2	21
BTR-180	67-1/2	4-1/2	62	53-5/8	20-1/2	21
BTR-197	75	4-1/2	70	61-5/8	20-1/2	21
BTR-199	67-1/2	4-1/2	62	53-5/8	20-1/2	21
BTR-200(A)	72	4-1/2	65-1/8	55-7/8	19-3/4	23
BTR-250*(A)	72	4-1/2	65-1/8	55-7/8	19-3/4	23
BTR-251*(A)	75	4-1/2	65-3/4	57-1/4	20	N/A
BTR-275*(A)	72	4-1/2	65-1/8	55-7/8	19-3/4	23
BTR-305 (A)	75	4-1/2	65-3/4	57-1/4	20	N/A
BTR-365 (A)	79-1/2	4-1/2	70-1/4	62-1/2	22-1/2	23
BTR-400 (A)	75-1/2	4-1/2	67-1/2	58-1/4	26-3/4	23
BTR-500 (A)	81-1/2	17-1/2	77-1/4	67-1/2	27	21

Model Number	Dimensions in Inches				Approx. Shipping Weight (lbs)	
	G	H	I	J	Standard	ASME
BTR-120*	1/2	51-7/8	6	27-3/4	400	-
BTR-154	1/2	54-5/8	6	27-3/4	470	-
BTR-180	1/2	54-5/8	6	27-3/4	470	-
BTR-197	1/2	62-5/8	6	27-3/4	603	-
BTR-200(A)	1/2	56-3/8	6	30-1/4	630	725
BTR-250*(A)	1/2	56-3/8	8	30-1/4	630	725
BTR-251*(A)	1/2	58-3/4	8	27-3/4	750	862
BTR-275*(A)	1/2	56-3/8	8	30-1/4	630	725
BTR-305 (A)	1/2	58-3/4	8	27-3/4	750	862
BTR-365 (A)	3/4	63	8	27-3/4	725	833
BTR-400 (A)	3/4	59	8	30-1/4	760	874
BTR-500 (A)	1	67-1/2	8	27-3/4	812	857

Specify when ordering propane (LP) gas.

*Model BTR 120 is shipped with 6" x 5" flue outlet adapter. Models BTR 250, 251 and 275 are shipped with a 8" x 6" flue outlet adapter.

Standard models certified from sea level to 2,000 ft. elevation. Order SMR S54 for elevations up to 8,000 ft.

BTR-500 model features induced draft design and no damper.

MASTER-FIT® ULTRA-LOW NOx



80% Thermal Efficiency means Lower Operating Costs

Fan Assisted Combustion

- The blower is built into the low NOx burner assembly
- Complies with California SCAQMD Rule 1146.2 and other Air Quality Management Districts with similar NOx emission requirements of 14 ng/J or 20 ppm

Air-Flapper

- A stainless steel air flapper is used inside the premix system to replace externally mounted flue damper to minimize the standby heat loss and to minimize the overall heater height

Metal Venting

- Rated Category I Appliance. Uses standard double wall type "B" vent.
- Can be commonly vented with other Category I appliances
- Vent connects directly to the vent connector outlet
- An excellent choice for retrofit and upgrade installations

3-Year Limited Tank/1-Year Limited Parts Warranty

- For complete warranty information, consult written warranty or go to hotwater.com



Model Number	Gallon Capacity	Input BTU/HR	Recovery Capacity GPH @ 100°F Rise
BTL-120	81	120,000	115
BTL-154	81	154,000	148
BTL-180	81	180,000	173
BTL-198	81	199,000	191
BTL-199	100	199,000	191
BTL-250	100	250,000	240
BTL-275	100	275,000	264
BTL-310	86	310,000	298
BTL-366	86	366,000	352
BTL-400	86	390,000	375
BTL-250A	100	250,000	240
BTL-275A	100	275,000	264
BTL-310A	86	310,000	298
BTL-366A	86	366,000	352
BTL-400A	86	390,000	375

Electrical characteristics—120V-60 Hz A. C., 5.0A.

(A) after model number designates ASME construction.

LEG KITS FOR UL SANITATION TO MEET NSF-5 (increases overall height by 4").

BTL models not available in LP gas.

Line drawings and dimensions on the following page.

COMMERCIAL GAS

MASTER-FIT® ULTRA-LOW NO_x

(CONTINUED)

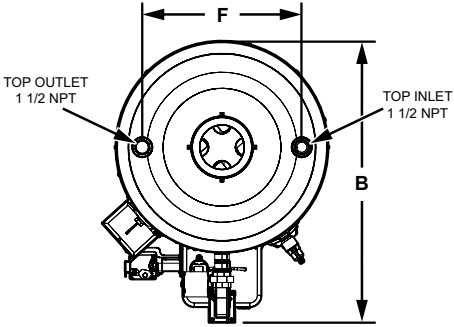

TOP VIEW

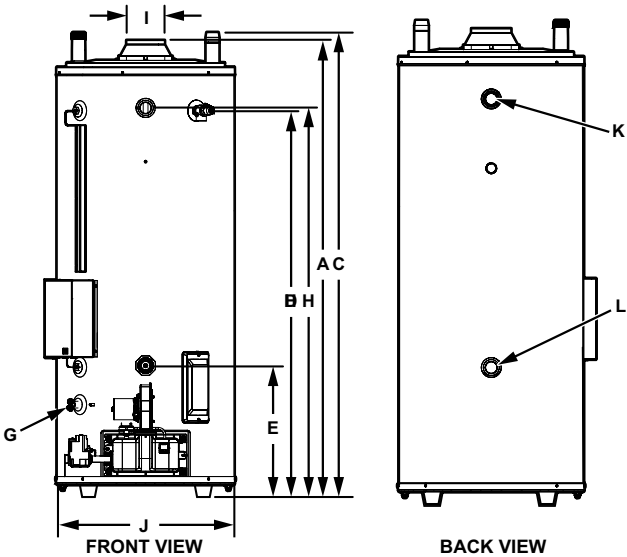

FRONT VIEW

BACK VIEW

Letter	BTL-120, 154, 180, 198	BTL-199, 250(A), 275(A)	BTL-310(A), 366(A), 400(A)
	Dimensions in Inches		
A	63-3/4	71-3/4	71-3/4
B	37	37	37
C	65	73	73
D	52-3/4	60-3/4	60-3/4
E	20-3/4	20-1/2	20-1/2
F	21	21	21
G	3/4 NPT		
H	53	61	61
I	6	6	6
J	27-3/4	27-3/4	27-3/4
K	1-1/2 NPT		
L	1-1/2 NPT		

Approx. Shipping Weight (lbs)	BTL-120, 154, 180, 198	BTL-199, 250(A), 275(A)	BTL-310(A), 366(A), 400(A)
Standard	650	750	810
ASME	N/A	800	860

Electrical characteristics—120V-60 Hz A. C., 5.0A.

(A) after model number designates ASME construction.

LEG KITS FOR UL SANITATION TO MEET NSF-5 (increases overall height by 4").

BTL models not available in LP gas.

COMMERCIAL GAS CONSERVATIONIST® BT



Glasslined Tank

- Maximizes tank life.
- Fully Automatic Controls with Safety Shutoff
- Accurate, dependable control system requires no electric connections
- Fixed automatic gas shutoff device for added safety
- Not recommended for 180°F sanitizing

Heavy Gauge Steel Jacket

- Finished with baked enamel over bonderized undercoat

Foam Insulation

- Saves fuel, helps reduce standby heat loss
- Low NOx

Complies with Texas and other Districts Requirements for NOx Emissions Less than 40 ng/j

Easy-to-Install

- Completely factory-assembled
- Only gas, water and vent connections need be made
- All connections are located in front and top of heaters for ease of installation and service

3-Year Limited Tank / 1-Year Limited Parts Warranty

- For complete warranty information, consult written warranty or go to hotwater.com



Low Lead Content



WATER QUALITY



Green Choice
The Greenest of Green



GAS-FIRED
LISTED



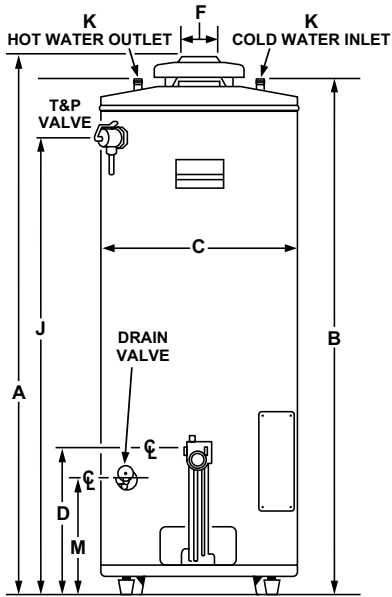
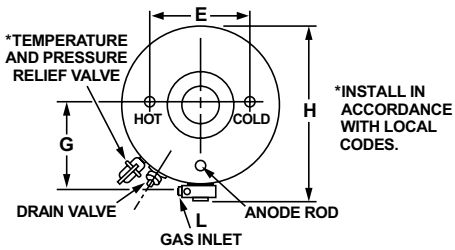

Model Number	Gallon Capacity	Input Rating BTU/HR	Recovery Capacity GPH @ 100°F Rise	Approx. Shipping Weight (lbs)
BT-80	74	75,100	73	275
BT-100	98	75,100	73	350

Model Number	Dimensions in Inches					
	A	B	C	D	E	F
BT-80	61-1/8	58-1/2	26-1/2	15-3/16	16	4
BT-100	68-5/8	66-1/2	27-3/4	15-3/16	16	4

Model Number	Dimensions in Inches					
	G	H	J	K	L	M
BT-80	14-1/2	29-11/16	54-1/4	1	1/2	11-15/16
BT-100	15-3/4	30-15/16	54-1/4	1	1/2	11-15/16

NSF leg kit 100111360.
Specify when ordering (LP) gas.

COMMERCIAL GAS

CONSERVATIONIST® POWER VENT



Approval Rating and Certification

- All models comply with ANSI Z21.10.3/CSA 4.3 and ASHRAE/IES 90.1-2004
- Meets Texas and other low NOx areas requiring 40 ng/J
- All models are approved for use in combined appliance applications

CFC Free Foam Insulation

- Minimize radiant heat loss

Dip Tube

- Carries inlet water deep into the tank

Hot Surface Ignition

- Has a solid state ignition surface that does not flutter or blow out
- Provides increased reliability and efficiency over spark ignition systems
- Eliminates the pilot and saves energy

User-Friendly

- State-of-art electronic gas control provides more precise temperature control
- LED control light displays operation status and diagnostics

3-Year Limited Tank/1-Year Limited Parts Warranty

- For complete warranty information, consult written warranty or go to hotwater.com



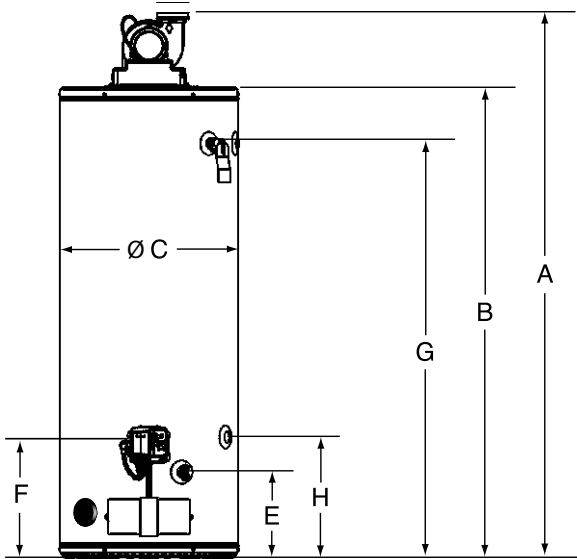
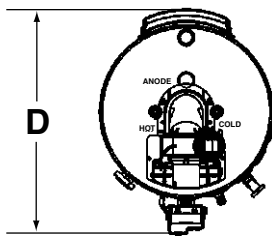

Model Number	Gallon Capacity	Btuh Input	Approx. Shipping Weight
BTF-80	75	76,000	277 lbs

Model Number	Dimensions in inches			
	A	B	C	D
BTF-80	70-5/8	61-1/4	26	33-1/8

Model Number	Dimensions in inches			
	E	F	G	H
BTF-80	11	13-1/4	53	15-1/4

Recovery capacity based on 81% thermal efficiency.
 Available in LP (Propane) gas.
 Can be installed up to 10,100 feet without alteration.

COMMERCIAL GAS

CONSERVATIONIST® POWER DIRECT VENT



DynaClean™ Diffuser Dip Tube

- Helps reduce lime and sediment buildup and maximizes hot water output
- Made from long-lasting PEX cross-linked polymer

Blue Diamond® Glass Coating

- Provides superior corrosion resistance compared to the industry-standard glasslining

Hot Surface Ignition

- Has a solid state ignition surface that does not flutter or blow out
- Provides increased reliability and efficiency over spark ignition systems. Eliminates the pilot and saves energy

Standards

- Design-certified by CSA International, according to ANSI Z21.10.3-CSA 4.3 standards governing storage-type water heaters
- Meets the thermal efficiency and standby loss requirements of the U.S. Department of Energy and current edition of ASHRAE/IES 90.1

3-Year Limited Tank/1-Year Limited Parts Warranty

- For complete warranty information, consult written warranty or go to hotwater.com



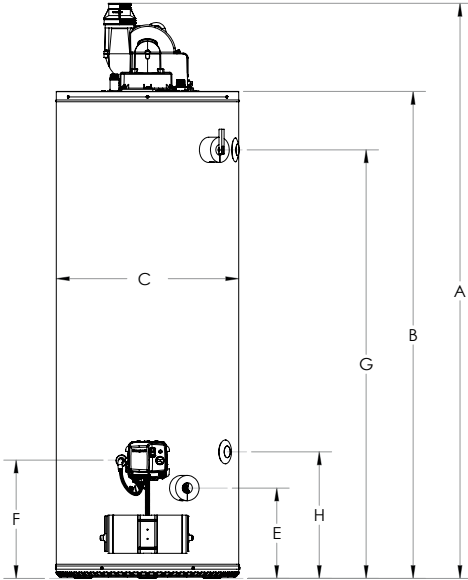
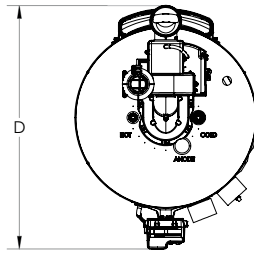

Model Number	Gallon Capacity	Btuh Input	Approx. Shipping Weight (lbs)
BPD-80	75	72,000	277

Model Number	Dimensions in Inches							
	A	B	C	D	E	F	G	H
BPD-80	70-5/8	61-1/4	26	33-1/8	11	13-1/4	53	15-1/4

Specify when ordering propane (LP) gas.

Can be installed up to 10,100 feet without alteration.

Recovery capacity based on 81% thermal efficiency.

CONSERVATIONIST® ULTRA-LOW NOx



Code Compliance

- The Ultra-Low NOx atmospheric vent commercial gas water heater which meets the thermal efficiency and standby loss requirements of the U.S. Department of Energy and Current Edition ASHRAE/IES 90.1

Fully Automatic Controls with Safety Shutoff

- Accurate, dependable control system requires no electric connections
- Fixed automatic gas shutoff device for added safety
- Not recommended for 180° F sanitizing

Heavy Gauge Steel Jacket

- Finished with baked enamel over bonderized undercoat

Foam Insulation

- Saves fuel, helps reduce standby heat loss

Ultra-Low NOx Emissions

- Complies with SCAQMD Rule 1146.2 and other Air Quality Management Districts with similar requirements of 14 ng/J or 20 ppm

Easy-to-Install

- Completely factory-assembled
- Only gas, water and vent connections need to be made
- All connections are located in front and top of heaters for ease-of-installation and service

3-Year Limited Tank and 1-Year Limited Parts Warranty

- For complete warranty information, consult written warranty or go to hotwater.com

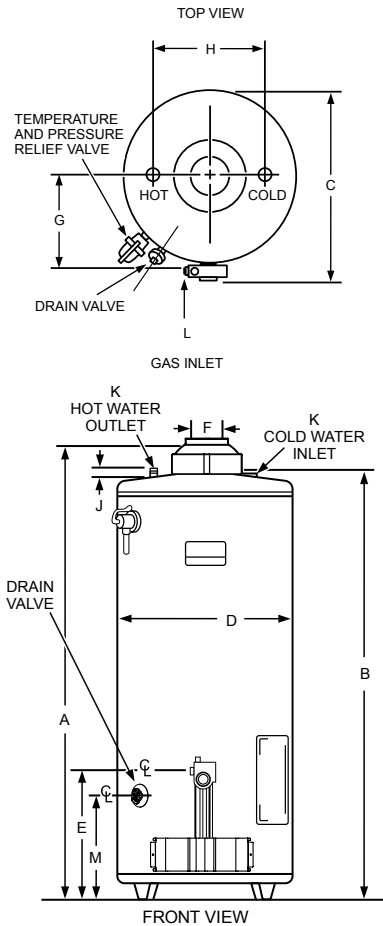

Model Number	Gallon Capacity	Input BTU/hr	Recovery Capacity GPH @ 100°F Rise	Approx. Shipping Weight (lbs)
BL-80 **	74	75,100	73	285
BL-100*	98	75,100	74	350

Dimensions in Inches					
Model Number	A	B	C	D	E
BL-80 **	62-1/16	58	29-1/2	25-1/4	15-7/8
BL-100*	70-1/2	66-1/2	30-15/16	27-3/4	15-3/16

Dimensions in Inches							
Model Number	F	G	H	J	K	L	M
BL-80 **	4	15-1/4	16	2	1	1/2	12-1/2
BL-100*	4	15-3/4	16	1-1/4	1-1/4	1/2	11-15/16

Natural gas only.

*Recovery rating based on 81% thermal efficiency

**Recovery rating based on 80% thermal efficiency

COMMERCIAL GAS

POWER BURNER LIGHT DUTY



Power Gas Burner

- Electronic flame safeguard control with direct spark ignition
- Redundant gas valves for added safety
- Power gas burner requires 120V, 60Hz service
- Non-forced-draft burner; negative draft required in vent piping

Fully Automatic Controls with Safety Shutoff

- High temperature limit control (manual reset)
- Dual thermostats for accurate temperature control

Glass Coating

- Exclusive process provides superior protection against corrosion

3-Year Limited Tank and 1-Year Limited Parts Warranty

- For complete warranty information, consult written warranty or go to hotwater.com



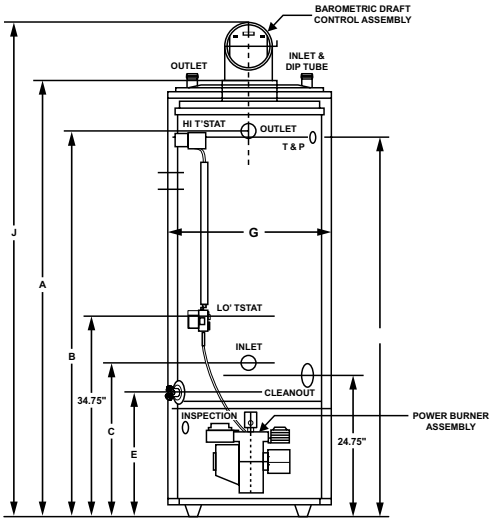
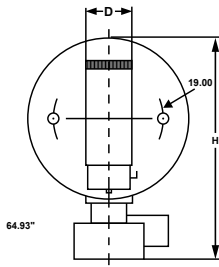

Model Number	BTU Input Per Hour	Tank Size
BTP-270(A)	270,000	81
BTP-370(A)**	370,000	81

Model Number	GPH or LPH	Recovery Gallons Per Hour Temperature Rise	Maximum Amperes 120V, 60 Hz, 1
		100°	
BTP-270(A)	GPH	262	5
BTP-370(A)**	GPH	359	5

Model Number	Dimensions in Inches				
	A	B	C	D	E
BTP-270(A)	74-3/4	65	26-3/4	6	21-3/8
BTP-370(A)**	74-3/4	65	26-3/4	6	21-3/8

Model Number	Dimensions in Inches			Approx. Shipping Weight	
	G	H	J	Standard	ASME
BTP-270(A)	27-3/4	38	85-1/4	547 lbs	632 lbs
BTP-370(A)**	27-3/4	38	85-1/4	547 lbs	632 lbs

** BTP 370 available in Natural Gas only.

COMMERCIAL GAS

LOW NO_x POWER BURNER



Venting Options

- BTP models designed for conventional atmospheric vertical venting
- Barometric draft regulating damper provided. Order Vent Kit Part #100125540
- BTPV models designed for horizontal atmospheric sidewall venting or direct venting
- For sidewall venting order Vent Kit Part #100125500
- For direct venting order Vent Kit Part #100131270

Low NO_x Power Gas Burner (Natural Gas Only)

- Pre-mix design with internal Flue Gas Recirculation (FGR)
- Safety features include internal blocked flue sensor, separate pilot system, internal thermal cutoff and anti-flashback barrier

Fully Automatic Controls

- Including safety shut-off, high-temperature limit control
- Dual thermostat, adjust from 120°F to 180°F
- Factory start-up included; required for activating and assuring maximum performance.

3-Year Limited Tank and 1-Year Limited Parts Warranty

- For complete warranty information, consult written warranty or go to hotwater.com



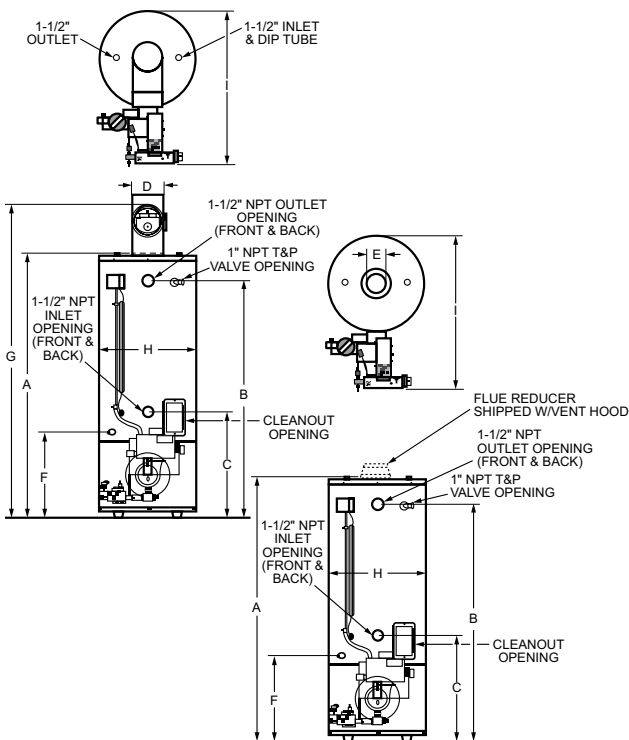

Model Number	Gallon Capacity	Input/BTU/HR Natural Gas	Recovery Capacity GPH @ 100°F Rise	Approx. Shipping Weight (lbs)
BTP(V)-540A	85	540,000	523	950
BTP(V)-650A	85	650,000	630	950
BTP(V)-740A	85	740,000	718	950

Model Number	Dimensions in Inches				
	A	B	C	D	E
BTP(V)-540A	80-3/4	73	32-1/4	9	26-1/2
BTP(V)-650A	80-3/4	73	32-1/4	9	26-1/2
BTP(V)-740A	80-3/4	73	32-1/4	9	26-1/2

Model Number	Dimensions in Inches			
	F	G	H	I
BTP(V)-540A	26-1/2	93	29-1/2	48-1/2
BTP(V)-650A	26-1/2	93	29-1/2	48-1/2
BTP(V)-740A	26-1/2	93	29-1/2	48-1/2

Not available in propane (LP).

Vent Kit included in unit price if ordered with heater.

Authorizes start-up service included; required to activate warranty. Consult local factory representative (Continental U.S. only)

CONSERVATIONIST® DURACLAD OIL-FIRED TANK-TYPE



Efficient Combustion Chamber

- Precast, high temperature combustion chamber made of alumina silica ceramic fiber
- Engineered for maximum insulation and heat reflection
- Unique design assures more complete combustion by stabilizing flame pattern

Interrupted Ignition

- Reduces electrical consumption

Two Hand-hole Cleanouts

- Allows easy cleaning on standard models COF-385 and larger and ASME models

Easy-to-Install Burner

- Three-bolt mounting of burner assures easy installations.

3-Year Limited Tank and 1-Year Limited Parts Warranty

- Factory Start-Up included: required for activating warranty and assuring maximum operating performance (Continental U.S. only)
- For complete warranty information, consult written warranty or go to hotwater.com



ASME

Available on
COF-315 and higher

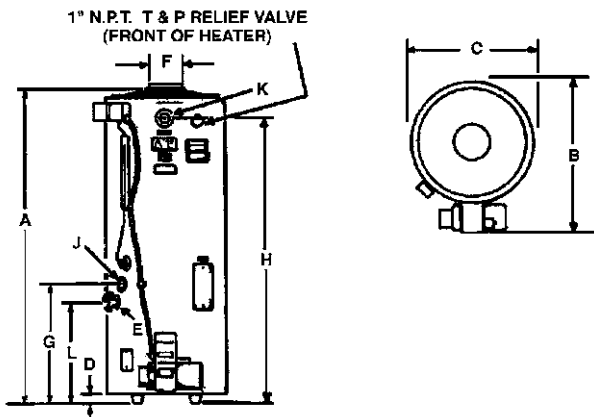

Model Number	Gallon Capacity	Input BTU/HR	Recovery Capacity GPH @ 100° F Rise*	Firing Rate in GPM	Approx. Shipping Weight (lbs)	
					Standard	ASME
COF-199†	86	199,000	191	1.42	553	N/A
COF-245	86	245,000	235	1.75	554	N/A
COF-315	84	315,000	302	2.25	554	657
COF-385	75	385,000	369	2.75	624	742
COF-455	75	455,000	436	3.25	700	747
COF-700	69	700,000	671	5	739	822

Model Number	Dimensions in Inches				
	A	B	C	D	E
COF-199†	74-1/2	36-3/4	27-3/4	2	3/4 NPT
COF-245	74-1/2	36-3/4	27-3/4	2	3/4 NPT
COF-315A	74-1/2	36-3/4	27-3/4	2	3/4 NPT
COF-385A	73-3/4	36-3/4	27-3/4	2	3/4 NPT
COF-455A	73-3/4	36-3/4	27-3/4	2	3/4 NPT
COF-700A	73-3/4	36-3/4	27-3/4	2	3/4 NPT

Model Number	Dimensions in Inches					
	F	G	H	J	K	L
COF-199†	8	26-5/8	74-1/2	1-1/2 NPT	1-1/2 NPT	22-3/4
COF-245	8	26-5/8	74-1/2	1-1/2 NPT	1-1/2 NPT	22-3/4
COF-315A	8	26-5/8	74-1/2	1-1/2 NPT	1-1/2 NPT	22-3/4
COF-385A	8	24-3/4	73-3/4	1-1/2 NPT	1-1/2 NPT	23-7/16
COF-455A	8	24-3/4	73-3/4	1-1/2 NPT	1-1/2 NPT	23-7/16
COF-700A	8	30-3/16	79-3/16	1-1/2 NPT	1-1/2 NPT	28-7/8

*Based on No. 2 fuel oil. All models have 1/8 HP motor.

Add "A" to the end of the model number for ASME tanks. (COF 315A - COF-700A only)

†Model supplied with Flue reducer which should be installed on top cover.

COMMERCIAL ELECTRIC LIGHT-SERVICE



Designed for light duty commercial applications with intermittent hot water loads.

Glasslined Tank

- Tank interior is coated with glass specially designed by A. O. Smith for water heater use

Heating Elements

- Two 4.5 KW zinc plated copper sheathed elements are standard

Standard Voltages

- The standard voltage is 240V single phase

Top Mounted Recessed Junction Box

Controls

- Thermostat is adjustable through a range of 120° to 181°F with a manual reset high temperature cutoff
- The heater is wired for non-simultaneous single phase operation

Coregard™ Anode Rod

- Our anode rods have a stainless steel core that extends the life of the anode rod allowing superior tank protection for longer than standard anode rods

Enhanced-Flow Brass Drain Valve

- Solid brass, tamper resistant, enhanced-flow, ball type, drain valve

Maximum Working Pressure 150 psi

Factory Installed CSA Certified and ASME Rated Temperature and Pressure Relief Valve

Certified to UL 1453 for Commercial Electric Water Heaters

Compliance

- Meets the standby loss requirements of the U.S. Department of Energy and current edition of ASHRAE/IES 90.1

Warranty

- 6-Year limited tank/1-Year limited parts.
- For complete information consult the written warranty or hotwater.com

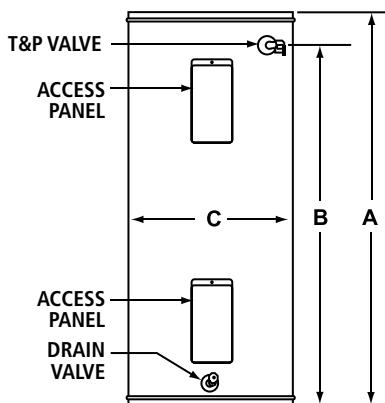
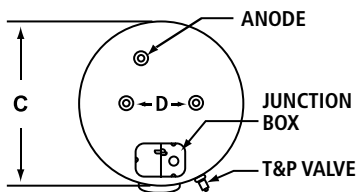

Model Number	Gallon Capacity	Standard Element Wattage 240 VAC	Dimensions in Inches				Approx. Shipping Weight (lbs)
			A	B	C Diameter	D	
LTE 66D	66	4500	60-1/4	53	22	8	146
LTE 80D	80	4500	60-1/2	52-1/4	24	8	175
LTE 120D	119	4500	61-1/2	54-1/2	28	8	268

Not available with top mounted T&P valve option

Element Wattage (Upper/Lower)	U. S. Gallons/Hr at Temperature Rise Indicated	
	F°	100
Non-Simultaneous Operation		
/1500	GPH	6
/2000	GPH	8
/2500	GPH	10
3000/3000	GPH	12
4000/4000	GPH	16
4500/4500	GPH	18
5000/5000	GPH	20
6000/6000	GPH	24
Simultaneous Operation		
3000/3000	GPH	24
4000/4000	GPH	32
4500/4500	GPH	36
5000/5000	GPH	41
6000/6000	GPH	49

COMMERCIAL ELECTRIC

DEN/DEL ELECTRIC DURA-POWER™



Glasslined Tank

- Thirteen sizes, 6 thru 119 gallon capacity
- Tank interior is coated with glass specially designed by A. O. Smith for water heater use

Elements

- Zinc plated copper sheaths for longer life
- Medium watt density means lower surface temperature to minimize scale build-up and more surface to heat water
- Element sizes from 1.5 to 6 KW. Maximum input 12 KW

Standard Voltages

- 120, 277 single phase and 208, 240 and 480V unbalanced three-phase delta; easily converted to single-phase at terminal block (except 208V with 6000 watt elements).
- Single element heater, single-phase only

Terminal Block

- Factory-installed. Just bring the service to heater and connect to block
- Terminal block not supplied on 120V & 277 volt models (No junction box on DEL6-20)

Element Wattage (Upper/Lower)	U. S. Gallons/Hr at Temperature Rise Indicated	
	F°	100
Non-Simultaneous Operation		
/1500	GPH	6
/2000	GPH	8
/2500	GPH	10
3000/3000	GPH	12
4000/4000	GPH	16
4500/4500	GPH	18
5000/5000	GPH	20
6000/6000	GPH	24
Simultaneous Operation		
3000/3000	GPH	24
4000/4000	GPH	32
4500/4500	GPH	36
5000/5000	GPH	41
6000/6000	GPH	49

6 gallon model not available above 3.0 kW.
Single element heaters available in single phase only.

HOT WATER OUTLET DEL-6

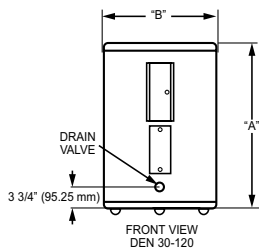
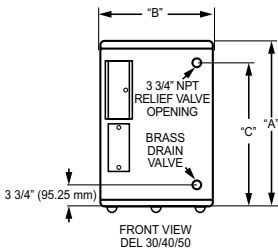
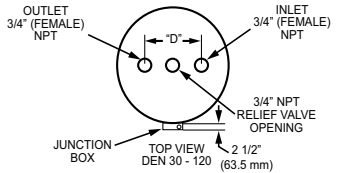
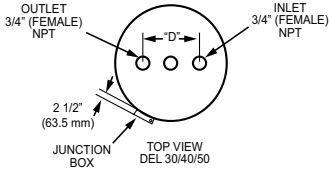
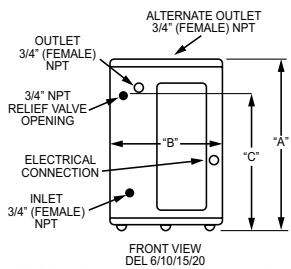
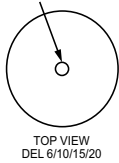

Model Number	Gallon Capacity	Dimensions in Inches				Approx. Shipping Weight (lbs.)
		A	B	C	D	
Compact Models						
DEL-6S	6	15-1/2	14-1/4	11	N/A	35
DEL-10S	10	18-1/4	18	12-1/2	N/A	54
DEL-15S	15	26	18	20-1/2	N/A	58
DEL-20S	20	22-1/4	21-3/4	15-3/8	N/A	73
Lowboy Models						
DEL-30D	30	30-7/8	21-3/4	24-1/8	8	100
DEL-40D	40	32-1/4	24	25-9/16	8	125
DEL-50D	50	32-1/4	26-1/2	25-1/8	8	166
Tall Models						
DEN-30D	30	34-1/2	20-1/2	N/A	8	98
DEN-40D	40	45-1/8	20-1/2	N/A	8	113
DEN-52D	50	54-7/8	20-1/2	N/A	8	131
DEN-66D	66	60-3/4	21-3/4	N/A	8	176
DEN-80D	80	59-3/8	24	N/A	8	211
DEN-120D	119	62-7/16	29-3/8	N/A	8	326

S= Single Element D= Dual Elements.

Dual element models wired for 3-phase 208/240/480 volt.

Field convertible to 1-phase as long as amp does not exceed 48 Amps.

COMMERCIAL ELECTRIC GOLD Xi SERIES



Advanced Electronic Control

- Plain English text and animated icons display diagnostics

Economy Mode Operation Lowers the Operating Set Point and Reduces Operating Costs

Thermostatic Linear Sequencing Control Helps Reduce Current Surges and Provides Accurate Control of Water Temperature

Incoloy Elements

- All DVE models ship standard with incoloy elements
- Incoloy elements provide long life with superior scaling resistance

Standard Voltages

- 208, 240, 277, 480V single-phase and three-phase delta
- Convertible from three-phase to single-phase (in field) and vice versa (except 208/54kW) 277 single-phase only

Element availability

- DRE/DVE heaters available from 3kW to 54 kW with recoveries of 25 to 837 GPH at a 100°F rise

3-Year Limited Tank and 1-Year Limited Parts Warranty

- For complete warranty information, consult written warranty or go to hotwater.com



ASME/CRN
(optional)



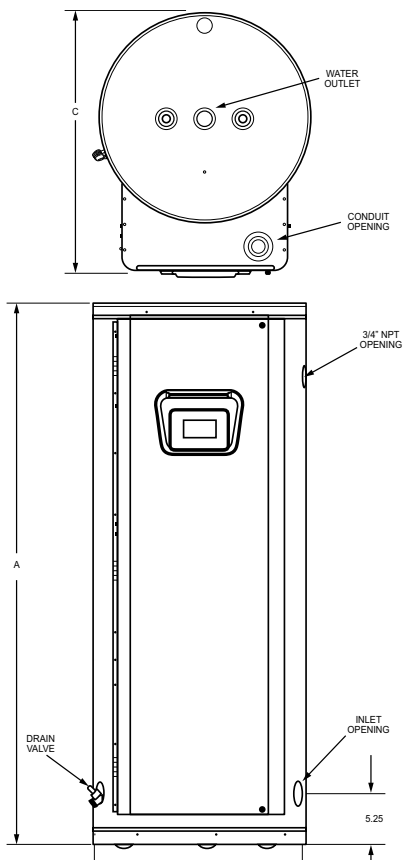

Model Number	Gallon Capacity	Dimensions in Inches			Approx. Shipping Weight (lbs)
		A	B	C	
DVE-52	50	55-3/4	21-3/4	27	265
DVE-80	80	60-1/4	25-1/2	31	280
DVE-120	119	62-1/4	29-1/2	35	390

See specification sheets or contact your local rep for optional kW's available.

COMMERCIAL ELECTRIC

GOLD SERIES



Incoloy Elements

- DRE models ship with incoloy elements (see spec sheet for kW options)
- Incoloy elements provide long life and superior scaling resistance

Fusing

- Protects all elements, thermostats, and internal wiring circuits against excess current flow
- Meets National Electrical Code requirements that non-ASME tanks must have internal fusing when current draw exceeds 48 amps
- Available as an option on Canadian-built heaters

Meets the Standby Loss Requirements of the U. S. Department of Energy and Current Edition of AHRAE/IES 90.1

Standard Voltages

- 208, 240, 277, 480V single-phase and three-phase delta
- Convertible from three-phase to singles-phase (in field) and vice versa (except 208/54kW) 277 single-phase only

Element availability

- DRE/DVE heaters available from 3kw to 54 KW with recoveries of 25 to 837 GPH at a 100°F rise

3-Year Limited Tank and 1-Year Limited Parts Warranty

- For complete warranty information, consult written warranty or go to hotwater.com



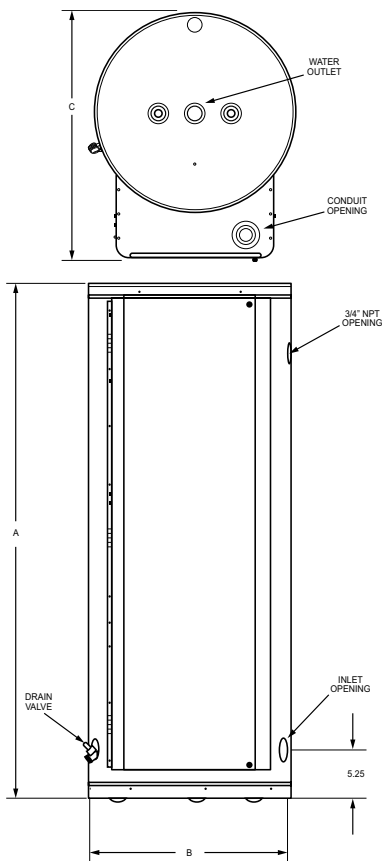

Model Number	Gallon Capacity	Dimensions in Inches			Approx. Shipping Weight (lbs)
		A	B	C	
DRE-52*	50	55-3/4	21-3/4	27	265
DRE-80	80	60-1/4	25-1/2	31	280
DRE-120	119	62-1/4	29-1/2	35	390

* DRE-52 is maximum 36kW.

See specification sheets or contact your local rep for optional kW's available.

COMMERCIAL ELECTRIC HEAVY-DUTY CUSTOM Xi



Advanced Electronic Control

- Provides Precise Temperature Control and Plain English Text with Animated Icons Display

Low-Water Cutoff—Remote Electronic Immersion-Type Probe to Prevent Energizing of the Elements, Eliminating Accidental Dry Firing

Incoloy-Sheath Heating Elements Standard

Factory-Wired, 120V Circuit Controls

Power-Circuit Fusing for System Protection

Glass-Lined Tank, with ASME Construction

CSA Certified and ASME Rated T&P Relief Valve

BACnet and Modbus Compatible with ICC Interface

3-Year Limited Tank and 1-Year Limited Parts Warranty

- For complete warranty information, consult written warranty or go to hotwater.com

Model Number	Tank Capacity		Maximum kW Input	Approx. Shipping Weight	
	Gallons	Litres		lbs.	Kg.
DSE-5A	5	19	3	82	37.2
DSE-10A	10	38	6	116	48.1
DSE-20A	20	76	18	145	65.7
DSE-30A	30	114	24	218	98.9
DSE-40A	40	151	36	245	111.1
DSE-50A	50	189	90	291	132.0
DSE-65A	65	246	90	344	156.0
DSE-80A	80	303	90	406	184.2
DSE-100A	100	379	90	419	190.1
DSE-120A	120	450	90	453	205.5

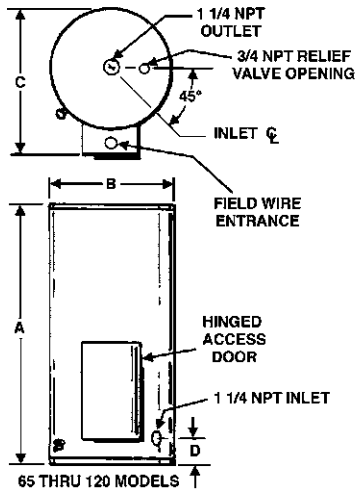
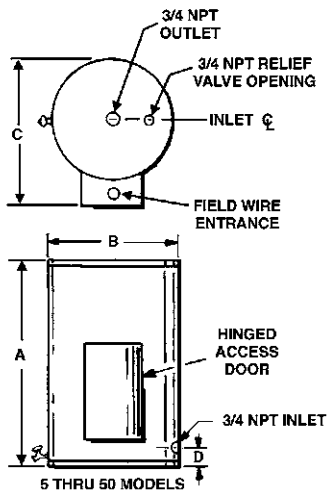

Model Number	Maximum kW Input	Dimensions in Inches			
		A	B	C	D
DSE-5A	3	22"	16"	24"	4.25"
DSE-10A	6	28.13"	18"	26"	5.25"
DSE-20A	18	31.75"	22"	28"	5.75"
DSE-30A	24	43.25"	22"	28"	5.75"
DSE-40A	36	54.75"	22"	28"	5.75"
DSE-50A	90	66.19"	22"	28"	5.75"
DSE-65A	90	57.25"	26.5"	32.5"	11.38"
DSE-80A	90	58.13"	28"	35"	12.5"
DSE-100A	90	70.25"	28"	35"	12.5"
DSE-120A	90	70.25"	30.13"	37"	12.5"

COMMERCIAL ELECTRIC

HEAVY-DUTY PREMIUM ELECTRIC

DVE/DHE DURA-POWER™



Advanced Electronic Control: A. O. Smith's New Proprietary Electronic Water Heater Control Provides Precise + or - 1°F Temperature Control that is Ideal for Industrial and Food Service Applications where Exact Temperatures of Hot Water are Needed

Modbus/BACnet compatible with optional Gateway interface

Call 888 WATER02 for more information

Progressive Modulating: Sizes the Input of Available Elements to Match Current Load Conditions; Rotates and Lead Lags Element Loads to Provide Long Life and Equal Wear.

Heavy-Duty Incoloy-Sheath Heating Elements

208V, 240V, 380V, 400V, 415V, 480V and 600V

Check with Factory for Voltages and kW's Not Listed

Factory-Installed Terminal Block

Heavy-Duty Magnetic Contactors

Factory-Wired, 120V Circuit Controls

Power-Circuit Fusing

Low-Water Cutoff

Glass-Lined Tank (Standard)

Handhole Clean-Out(s)

Color-Coded Circuitry

CSA Certified and ASME Rated T&P Relief Valve



ASME

Vertical Round Models 150-1000

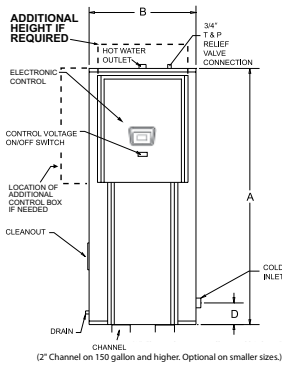

Vertical Square Models 1250-2500

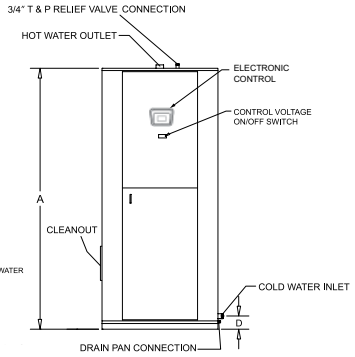

Top View

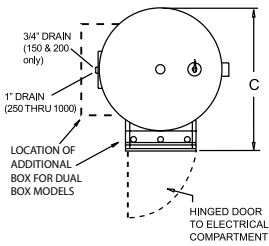

Top View

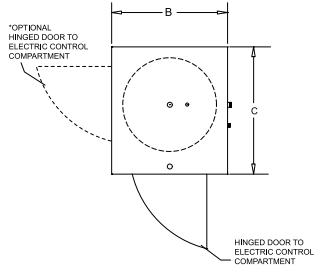

Horizontal Models

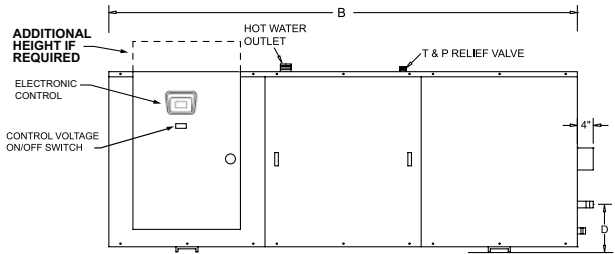

A & D ELEVATION FROM FINISHED FLOOR

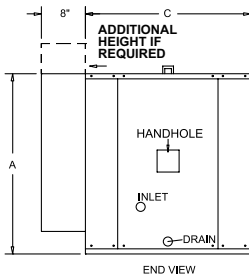

END VIEW

EXTRA PANEL BOX MAY BE NECESSARY FOR INPUTS HIGHER THAN 72KW. CONSULT FACTORY

*An oversized control panel may be required on models with inputs above 72 kW. An oversized control panel may increase the width and depth of the square jacket by up to 2".

COMMERCIAL ELECTRIC

HEAVY-DUTY PREMIUM ELECTRIC

DVE/DHE DURA-POWER™ (CONTINUED)

Model Number*	Max. KW	Gallon Capacity	Dimensions in Inches			
			A	B	C	D
Vertical Round Electric Storage Heater						
DVE-150A	144	150	65-1/2"	32"	38-3/4"	11-3/4"
DVE-200A	180	200	78"	32"	38-3/4"	11-3/4"
DVE-250A	216	250	92"	34"	40-3/4"	19-1/4"
DVE-300A	270	300	80"	40"	46-3/4"	20-3/4"
DVE-400A	360	400	80"	46"	52-3/4"	22-1/4"
DVE-500A	396	500	92"	46"	52-3/4"	22-1/4"
DVE-600A	396	600	92"	52"	60-3/4"	24-1/4"
DVE-800A	396	750	104"	52"	60-3/4"	24-1/4"
DVE-1000A	396	950	128"	52"	60-3/4"	24-1/4"
Vertical Square Electric Storage Heater						
DVE-1250A	900	1,250	132-1/2"	64-1/2"	64-1/2"	23-1/4"
DVE-1500A	900	1,500	128-1/2"	70-1/2"	70-1/2"	25-1/4"
DVE-2000A	900	2,000	124-1/2"	78-1/2"	78-1/2"	27"
DVE-2500A	900	2,500	146-1/2"	82-1/2"	82-1/2"	29"
Horizontal Square Electric Storage Heater						
DHE-150A	144	150	37"	68-1/2"	34-1/4"	12"
DHE-200A	180	200	37"	78"	34-1/4"	12"
DHE-250A	225	250	39"	90-1/4"	36-1/4"	13"
DHE-300A	270	300	45"	78-1/4"	42-1/4"	14-3/4"
DHE-400A	360	400	52"	78-1/4"	48-1/4"	16"
DHE-500A	450	500	52"	90-3/4"	48-1/4"	16"
DHE-600A	540	600	58"	90-3/4"	54-1/4"	13-1/2"
DHE-800A	720	750	58"	102-1/4"	54-1/4"	13-1/2"
DHE-1000A	900	950	58"	126-1/4"	54-1/4"	13-1/2"
DHE-1250A	900	1,250	64"	130-1/4"	60-1/4"	15"
DHE-1500A	900	1,500	70"	126-1/4"	66-1/4"	16"
DHE-2000A	900	2,000	82"	123-1/4"	78-1/4"	14"
DHE-2500A	900	2,500	82"	144-1/4"	78-1/4"	16-1/2"

Model Number*	Water Connection		Shipping Weight (lbs)
	Inlet Openings	Outlet Openings	
Vertical Round Electric Storage Heater			
DVE-150A	1-1/2"	1-1/2"	650
DVE-200A	1-1/2"	1-1/2"	750
DVE-250A	1-1/2"	1-1/2"	1,165
DVE-300A	2"	2"	1,350
DVE-400A	2"	2"	1,590
DVE-500A	2"	2"	1,700
DVE-600A	2-1/2"	2-1/2"	2,010
DVE-800A	2-1/2"	2-1/2"	2,450
DVE-1000A	2-1/2"	2-1/2"	3,160
Vertical Square Electric Storage Heater			
DVE-1250A	3"	3"	3,560
DVE-1500A	3"	3"	4,120
DVE-2000A	3"	3"	4,350
DVE-2500A	3"	3"	5,750
Horizontal Square Electric Storage Heater			
DHE-150A	2"	2"	1,180
DHE-200A	2"	2"	1,370
DHE-250A	2"	2"	1,450
DHE-300A	2"	2"	1,530
DHE-400A	2"	2"	1,750
DHE-500A	2"	2"	1,860
DHE-600A	2-1/2"	2"	2,340
DHE-800A	2-1/2"	2"	2,850
DHE-1000A	2-1/2"	2"	3,040
DHE-1250A	3"	3"	3,750
DHE-1500A	3"	3"	4,340
DHE-2000A	3"	3"	4,580
DHE-2500A	3"	3"	6,060

COMMERCIAL ELECTRIC

HEAVY-DUTY PREMIUM ELECTRIC

DVE/DHE DURA-POWER™ (CONTINUED)

kW Input	GPH 100°F Rise	Btu/hr Equivalent	Max. No. of Elements	No. of Control Steps	kW Per Element	No. of Contractors 240/480V
15	62	51,180	1	1	15	2/1
18	74	61,416	1	1	18	2/1
30	123	102,360	2	1	15	2/1
36	148	122,832	2	1	18	4/2
45	185	153,540	3	1	15	3/2
54	221	184,248	3	1	18	6/2
60	246	204,720	4	2	15	12/6
72	295	245,664	4	2	18	8/4
90	369	307,080	5	2	18	6/3
108	443	368,496	6	2	18	12/4
120	492	409,440	8	3	15	8/4
135	554	460,620	9	3	15	9/6
144	590	491,328	8	3	18	16/8
162	664	552,744	9	3	18	18/6
180	738	614,160	10	4	18	20/10
216	886	736,992	12	4	18	24/8
234	959	798,408	13	5	18	26/13
252	1,033	859,824	14	5	18	28/14
270	1,107	921,240	15	5	18	30/10
288	1,181	982,656	16	6	18	32/16
306	1,255	1,044,072	17	6	18	34/17
324	1,328	1,105,488	18	6	18	36/12
342	1,402	1,166,904	19	7	18	38/19
360	1,476	1,228,320	20	7	18	40/20
378	1,550	1,289,736	21	7	18	42/14
396	1,624	1,351,152	22	8	18	44/22
414	1,697	1,412,568	23	8	18	46/23
432	1,771	1,473,984	24	8	18	48/16

Models with over 72kW will require an extended control box, which increases the height.

Please consult factory for orders over 72kW

Complete model number includes the desired kw at the end, minimum installation

Clearances required: 30" from front, 12" from top and 24" from right side.

BACnet and Modbus connectivity available with the ICC Gateway device.

kW Input	Suggested Modulating Control Steps 240/480V	Amperage Draw				
		Single Phase		Three Phase		
		208V	240V	208V	240V	480V
15		72	63	42	36	18
18		87	75	50	44	22
30		144	125	83	72	36
36	4/2	174	150	100	87	44
45	3/2	216	188	125	108	54
54	3/2	260	225	150	130	65
60	4/3	289	250	167	144	72
72	4/4	Not Recommended	Not Recommended	200	174	87
90	3/3			250	217	109
108	4/4			300	260	130
120	4/4			333	289	144
135	4/4			375	325	162
144	4/4			400	347	174
162	8/6			450	389	195
180	8/8			500	434	217
216	8/8			600	519	260
234	8/8			650	563	282
252	8/8			700	607	304
270	12/10			750	649	325
288	12/12			800	692	347
306	12/12			850	736	368
324	12/12			900	780	390
342	12/12			950	822	412
360	12/12			1,000	865	435
378	14/14			1,050	909	455
396	15/16			1,100	952	477
414	16/16			1,150	995	498
432	16/16	1,200	1,040	520		

Complete model number includes the desired kW at the end (example: DVE-140-120)
 Minimum installation clearances required: 30" from front, 12" from top and 24" from right side
 150 gallon available in both tall (T) and short (S) models
 BACnet and Modbus connectivity available with the ICC Gateway device

COMMERCIAL HEAT PUMP

FULLY INTEGRATED HEAT PUMP



Energy Saving & Environmentally Friendly

- Heat pump transfers heat from surrounding area into the tank
- Industry leading 4.2 COP
- Multiple operating modes maximize efficiency while meeting specific hot water needs
- Integrated, large capacity tank enables heat pump to operate more frequently than electric elements, saving money
- Meets standby loss requirements of U.S. Department of Energy and current edition of ASHRAE 118.1

Commercial Performance

- First hour delivery of 150 GPH
- Electric heating element capacity of 12 kW (240Vac)
- Max. water temperature of 150° F. in Efficiency/Hybrid modes and 180° F. in Electric mode
- Ambient room temperature operating range of 20° to 110° F.
- Dual evaporator fans maximize performance and provide room cooling
- Low operating sound measured at 59 dB (A)

Ease of Operation

- Integrated design and pre-charged refrigeration system facilitates fast, easy installation
- Large touch screen LCD display allows for mode selection, provides run information and includes troubleshooting alerts and detail
- Three operating modes: Efficiency, Hybrid or Electric

Dependable & Long Lasting Design

- A. O. Smith-developed glass coated tank
- Tank rated at 160 PSI working pressure
- Commercial grade anode protects the tank and extends service life
- Electric elements have incoloy sheathing and provide excellent protection from oxidation and scaling

3-Year Limited Tank and 1-year Limited Parts/Compressor Warranty

- For complete warranty information, consult written warranty or go to hotwater.com

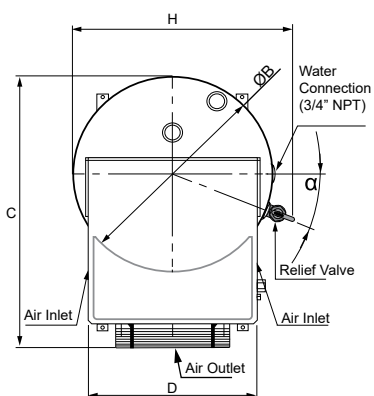
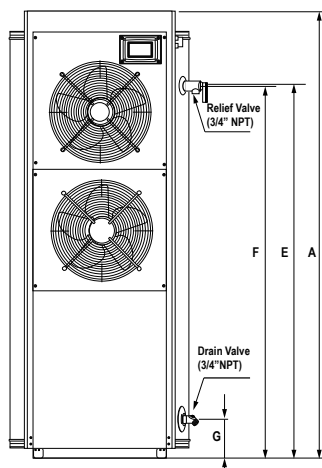

Model Number	Gallon Capacity	COP	Number of Elements
CAHP-120	119	4.2	2

Total Element Wattage (both elements @ 240V)	First Hour Delivery in Hybrid Mode (GPH)	Recovery in GPH at 100° Temperature Rise	Approx. Shipping Weight (lbs)
12,000	150	Efficiency = 41 Hybrid = 90 Electric = 50	620

Model Number	Dimensions			
	A	B	C	D
CAHP-120	69-11/16	28-1/32	39-11/64	23-5/8

Dimensions			
E	F	G	H
58-7/64	57-51/64	6-1/32	30-29/32

CIRCULATING WATER HEATER

XP HIGH EFFICIENCY WATER HEATERS



Up to 96% Thermal Efficiency

Fully Modulating with 5:1 Turndown

Advanced Electronics with Large Touchscreen Display and Built-In Lead/Lag Sequencing

Direct Vent Flexibility Up to 100 Feet

Matches with Storage Tank for Storage Flexibility

ASME Rated Relief Valve

160 lb. ASME Working Pressure

Factory-Supplied Bronze Circulating Pump

Adjustable Pump Delay

316L Stainless steel Heat Exchanger

Meets the Requirements of South Coast Air Quality Management District in Southern California and the Requirements of Texas Commission on Environmental Qualities.

5-Year Heat Exchanger and 1-Year Parts Limited Warranty

- For complete warranty information, consult written warranty or go to hotwater.com

XP



ASME

Recovery Capacities					
Model Number	BTU/HR Natural Gas Input	Water Flow	Temperature Rise		
			70	100	140
XWH-150	150,000	GPH	248	173	124
XWH-200	200,000	GPH	336	235	168
XWH-285	285,000	GPH	474	332	237
XWH-400	400,000	GPH	665	465	332
XWH-500	500,000	GPH	831	582	416
XWH-600	600,000	GPH	997	698	499
XWH-700	700,000	GPH	1,164	815	582
XWH-800	800,000	GPH	1,330	931	665

150 - 200

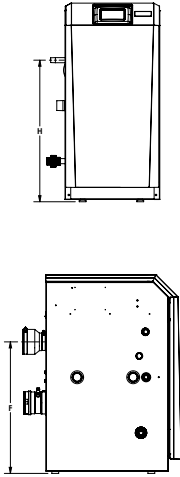

285 - 800

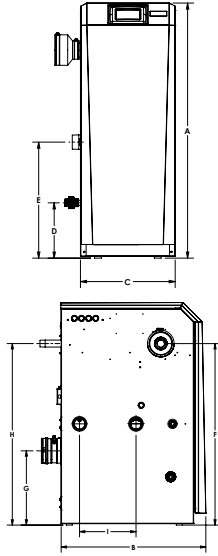

Model Number	Dimensions in Inches				
	A	B	C	D	E
XWH-285	42	20	15-1/2	9-1/4	19-1/4
XWH-400	42	27-1/4	15-1/2	9	19
XWH-500	42	31-3/4	15-1/2	9-1/4	19
XWH-600	42	46-1/2	15-1/2	9-1/4	19-1/4
XWH-700	42	40-1/2	15-1/2	9-1/4	19-1/4
XWH-800	42	45-1/2	15-1/2	9-1/4	19-1/4

Model Number	Dimensions in Inches			
	F	G	H	I
XWH-285	34-1/4	14	31-1/2	3-3/4
XWH-400	34-1/4	14	34-1/4	10-3/4
XWH-500	32-3/4	14	36-1/4	10-3/4
XWH-600	36-1/2	14	33-1/4	10-3/4
XWH-700	36-1/2	14	33-1/4	13-3/4
XWH-800	36-1/2	14	33-1/4	13-3/4

Model Number	Dimensions in Inches			
	A	B	C	D
XWH-150	32-3/4	18-1/4	15-1/2	6-3/4
XWH-200	32-3/4	22-1/4	15-1/2	6-3/4

Model Number	Dimensions in Inches				
	E	F	G	H	I
XWH-150	15-3/4	21-1/2	11-1/2	23-1/4	3-3/4
XWH-200	15-3/4	21-1/2	11-1/2	23-1/4	9-1/4

CIRCULATING WATER HEATER

XP^{PLUS} HIGH EFFICIENCY WATER HEATERS



Advanced Color Touchscreen Display

Operating Control Featuring Lead/Lag Sequencing

98% Thermal Efficiency

1.25 to 4.0 Million BTU/Hr

Firing Rate Modulation to 5:1

Less Than 20 PPM NO_x

Direct Vent Flexibility Up to 150 Ft.

5-Year Heat Exchanger and 1-Year Parts Limited Warranty

- For complete warranty information, consult written warranty or go to hotwater.com

XP^{PLUS}



ASME

CRN

Recovery Capacities

Model Number	BTU/HR Natural Gas Input	Water Flow	Temperature Rise °F
			100
PWH 1250NP	1,250,000	GPH	1,065
PWH 1500NP	1,500,000	GPH	1,497
PWH 2000NP	2,000,000	GPH	2,317
PWH 3000NP	3,000,000	GPH	3,000
PWH 4000NP	4,000,000	GPH	3,956

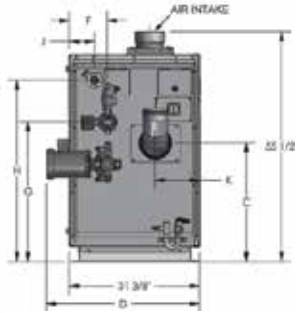
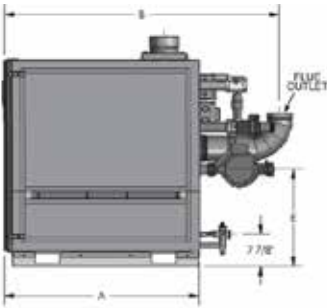
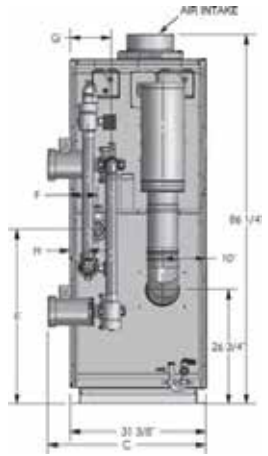
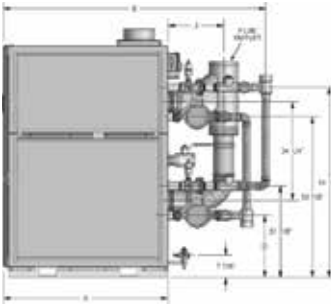

Models	PWH-1000		PWH-1300		PWH-1700	
Dimensions	Inches	mm	Inches	mm	Inches	mm
Flue Outlet Diameter	6	152	8	152	8	203
Air Intake Diameter	6	152	6	152	8	203
Wat Inlet	2 inch NPT				2-1/2 inch NPT	
Water Outlet	2 inch NPT				2-1/2 inch NPT	
Gas Inlet	2 inch NPT				2 inch NPT	
A	47	1199	49	1245	57	1448
B	67	1702	68	1727	76	1930
C	29	737	29	737	29	737
D	37	940	38	965	37	940
E	23	584	23	584	24	610
F	9	29	9	229	9	229
G	34	864	34	864	34	864
H	44	1118	45	1143	45	1143
J	6	152	6	152	6	152
K	11	279	11	279	11	279
L	12	305	11	279	12	305

COMMERCIAL WATER HEATER

BURKAY® GENESIS® DOMESTIC WATER HEATER

85% Thermal Efficiency

Electronic Control with Precise Temperature Management

Stage Gas Firing System - Prevents Short Cycling and Ensures Smooth Operation, Saves Fuel and Extends Product Life

Low NOx Operation

Copper Finned-Tube Heat Exchanger

Space-Saving Design: Optional Stack Rack Allows One Unit to be Stacked on Top of Another, Doubling Output within the Footprint of a Single Unit

Meets ASHRAE/IES 90.1-2004

Multiple Venting Options

Factory Start-Up Included

5-Year Heat Exchanger and 1-Year Parts Limited Warranty

- For complete warranty information, consult written warranty or go to hotwater.com



Burkay
GENESIS®



Model Number	Input MBH	Recovery Capacity GPH @ 100°F Rise	Approx. Shipping Weight (lbs)
GWH-400N	399	412	454
GWH-500N	500	515	467
GWH-650N	650	670	551
GWH-750N	750	773	611
GWH-1000N	990	1,020	843
GWH-1250N	1,260	1,298	939
GWH-1450N	1,440	1,484	1,035
GWH-1800N	1,800	1,855	1,168
GWH-2100N	2,070	2,133	1,285

When ordering propane change "N" to "P" in the model number (example GWH-750P).

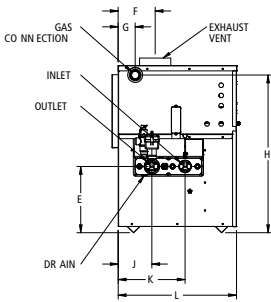

GWH-400 THRU GWH-750

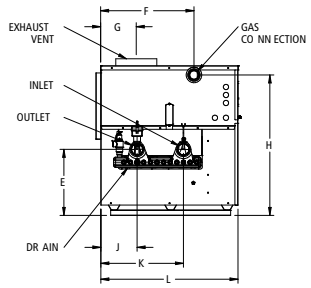

GWH-1000 THRU GWH-2100

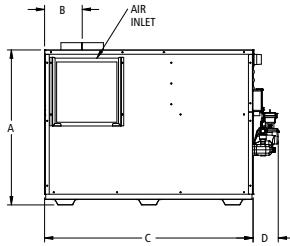

SIDE VIEW

Model Number	Dimensions in Inches					
	A	B	C	D	E	F
GWH-400N	31-1/2	7	37-5/8	8-7/8	12-1/2	7
GWH-500N	31-1/2	7	45-3/8	8-7/8	12-1/2	7
GWH-650N	31-1/2	8-1/2	56-3/4	8-7/8	12-1/2	8-1/2
GWH-750N	31-1/2	8-1/2	64	8-7/8	12-1/2	8-1/2
GWH-1000N	36	8-3/4	48-1/2	5-7/8	15-7/8	22-1/2
GWH-1250N	36	9-3/4	58-3/4	5-7/8	15-7/8	22-1/2
GWH-1450N	36	10-1/2	68-7/8	5-7/8	15-7/8	22-1/2
GWH-1800N	36	11	82-3/8	5-7/8	15-7/8	22-1/2
GWH-2100N	36	11	92-5/8	5-7/8	15-7/8	22-1/2

Model Number	Dimensions in Inches				
	G	H	J	K	L
GWH-400N	3-1/4	29-3/4	6-3/8	12-5/8	22-1/4
GWH-500N	3-1/4	29-3/4	6-3/8	12-5/8	22-1/4
GWH-650N	3-1/4	29-3/4	6-3/8	12-5/8	22-1/4
GWH-750N	3-1/4	29-3/4	6-3/8	12-5/8	22-1/4
GWH-1000N	8-1/2	33-3/4	8-3/4	19-7/8	33
GWH-1250N	9-3/4	33-3/4	8-3/4	19-7/8	33
GWH-1450N	10-1/4	33-3/4	8-3/4	19-7/8	33
GWH-1800N	10-7/8	33-3/4	8-3/4	19-7/8	33
GWH-2100N	10-7/8	33-3/4	8-3/4	19-7/8	33

When ordering propane change "N" to "P" in the model number (example GWH-750P).

COMMERCIAL WATER HEATER

VARIABLE FIRE™ HIGH-EFFICIENCY WATER HEATERS



Up to 85% Thermal Efficiency

Advanced Modulating Control with Venturi-Mixing Gas/Air Ratio System

Small Footprints, Zero Clearance to Combustibles on Sides of Unit

Category II and IV Listed: Requires the use of AL29-4C, a Vent Material That Resists the Effects of Corrosive Condensates

Complies with SCAQMD Rule 1146.2 and Other Air Quality Management Districts with Similar Requirements for Low NOx emissions

Capable of Firing from 100% to 25% (or a 4:1 Turndown Ratio) of the Rated Input, Based on the Current System Demand



Meets Thermal Efficiency and Standby Loss Requirements of the U.S. Department of Energy and Current Edition of ASHRAE/IES 90.1

Professional Start-Up Included - Required for Activating Warranty and Assuring Maximum Operating Performance

5-Year Heat Exchanger and 1-Year Parts Limited Warranty

- For complete warranty information, consult written warranty or go to hotwater.com

Model Number	BTU/Hr Input	Recovery Capacity GPH @ 100°F Rise	Approx. Shipping Weight (lbs)
VWH0500N	500,001	515	573
VWH0750N	750,000	773	622
VWH1000N	999,999	1030	662
VWH1500N	1,500,000	1545	1,118
VWH2000N	2,000,000	2061	1,187

Change "N" to "P" when ordering propane (LP) gas (Example: VWH-750-P).

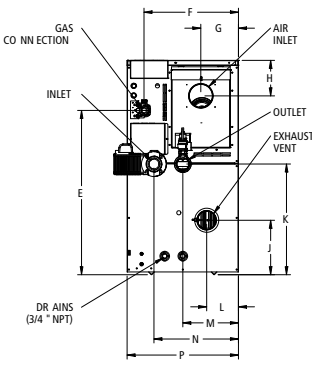

REAR VIEW
(VWH0500N-VWH1000N)

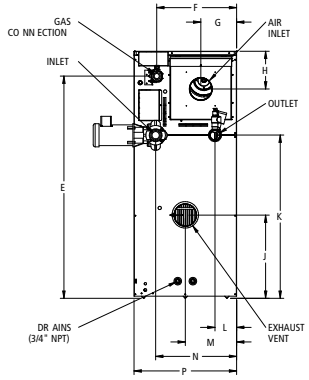

REAR VIEW
(VWH1500N-VWH2000N)

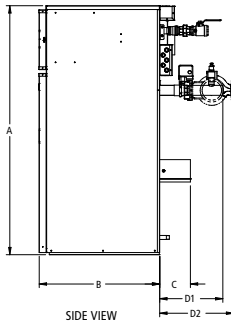

SIDE VIEW

*Pump shipped loose

Model Number	Dimensions in Inches							
	A	B	C	D1	D2	E	F	G
VWH-500N	44-1/2	30-3/8	6	12-1/2	15-1/8	34-1/8	19-5/8	7-3/4
VWH-750N	52-1/8	30-3/8	6	12-1/2	15-1/8	41-3/4	19-5/8	7-3/4
VWH-1000N	59-1/4	30-3/8	6	12-1/2	15-1/8	48-7/8	19-5/8	7-3/4
VWH-1500N	65-3/8	31-5/8	8	16-1/2	19-3/8	58-3/4	21-1/8	9-1/2
VWH-2000N	76-5/8	31-5/8	8	16-1/2	19-3/8	70	21-1/8	9-1/2

Model Number	Dimensions in Inches							
	H	J	K	L	M	N	P	
VWH-500N	7-3/8	11-3/8	23	6-1/2	11-1/2	17-1/2	23-1/8	
VWH-750N	7-3/8	11-3/8	30-1/2	6-1/2	11-1/2	17-1/2	23-1/8	
VWH-1000N	7-3/8	11-3/8	37-5/8	6-1/2	11-1/2	17-1/2	23-1/8	
VWH-1500N	9-1/2	22	43-1/4	5-3/4	13-1/2	21-3/8	27-1/8	
VWH-2000N	9-1/2	27-3/8	54-3/8	5-3/4	13-1/2	21-3/8	27-1/8	

Authorized start-up service included; required to activate warranty.(Continental U.S. Only).
Change "N" to "P" when ordering propane (LP) gas (Example: VWH-750-P).

COMMERCIAL WATER HEATER

BURKAY® ENERGY SAVER COPPER HEAT EXCHANGER



All Non-Ferrous Waterways

- Rustproof because water comes in contact with nothing but copper, brass or bronze
- Copper transfers heat eight times faster than ferrous metals yet offer remarkable structural strength without excessive weight
- Free from the effects of thermal shock

Efficiency Copper Coil Combustion Chamber

- Continuous coils of tightly wound copper tubing form a unique combustion chamber
- Water circulating thru the coils, around the flame, captures radiant heat which may otherwise be lost

High Efficiency Stainless Steel Burner

- Developed especially for A. O. Smith water heaters using the very latest burner principles

Forced Water Circulation Improves System Efficiency

- Water moving at 2 to 4 feet per second helps to prevent lime buildup and also scrubs extra heat from the copper coil combustion chamber

Model	Input Rating BTU/Hr. Natural & Propane Gas	Temperature Rise-100°F Gallons Per Hour
HW-120M	120,000	120
HW-160M	160,000	154
HW-200M	199,000	195
HW-225M	225,00 Nat. Gas Only	217

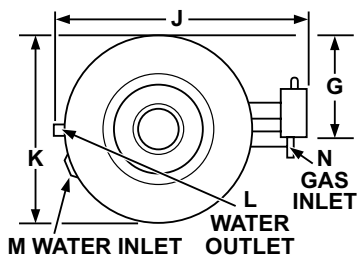
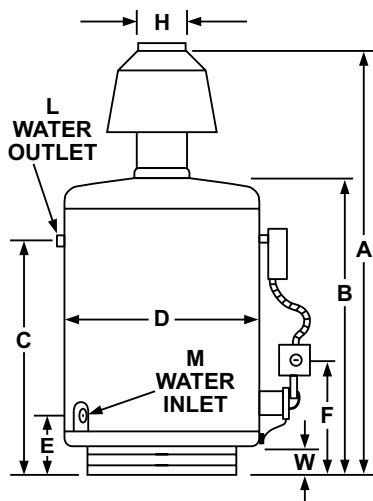

Models	HWH-120	HWH-160	HWH-200	HWH-225
Dimensions in Inches				
A	49-3/8	50-1/8	53-1/4	60
B	30-3/8	30-3/8	33-1/8	33-1/8
C	23-5/8	23-5/8	27-1/8	27-1/8
D	20-3/4	20-3/4	20-3/4	20-3/4
E	5-1/2	5-1/2	5-1/2	5-1/2
F	10	10	10	10
G	11-13/16	11-13/16	11-13/16	11-13/16
H	6	7	7	7
J	26-11/16	26-11/16	26-11/16	26-11/16
K	20-3/4	20-3/4	20-3/4	20-3/4
L	1-1/4 NPT	1-1/4 NPT	1-1/4 NPT	1-1/4 NPT
M	1 NPT	1 NPT	1 NPT	1 NPT
N	1/2 NPT	1/2 NPT	1/2 NPT	1/2 NPT
W	1-3/4	1-3/4	1-3/4	1-3/4
Approx. Shipping Weight	120 lbs.	155 lbs.	165 lbs.	175 lbs.

HOT WATER SUPPLY BOILERS

BURKAY® HWH GAS DOMESTIC WATER HEATERS & BOILERS



All Non-Ferrous Waterways

- All castings are made of bronze or brass
- All water tubes are made from copper
- Brazed joints or flare union construction make the boiler immune to the effects of thermal shock and thermal cycling
- A great boiler for domestic hot water supply

Efficiency Copper Coil Combustion Chamber

- The combustion chamber is a heat exchanger formed from a two passage coil of tightly wound continuous copper tube
- Water circulating through this coil surrounds the main burner and captures the radiant heat
- A wrap of insulation on the outside of the coil retains the heat captured by the circulating water



Model Number	Input Rating BTU/HR Natural & Propane (LP) Gas	Recovery Capacity GPH @ 100°F Rise	Approx. Shipping Weight (lbs)
HW-300	300,000	298	255
HW-399	399,000	392	301
HW-420	420,000	417	301
HW-520	520,000	516	381
HW-670 Nat.	660,000	646	381
HW-670 Prop	670,000	656	381

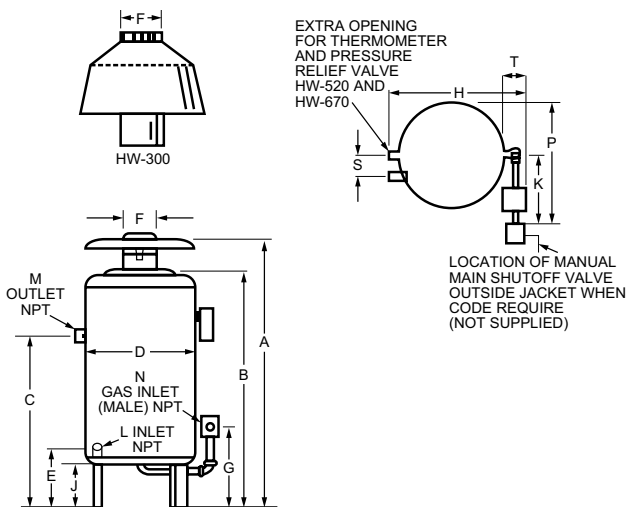

Dimensions in Inches		Models				
		HW-300	HW-399	HW-420	HW-520	HW-670
A	Overall height	65	57-1/8	57-1/8	68-5/16	68-5/16
B	Height to Top of Jacket	43-1/4	45-1/8	45-1/8	56-1/4	56-1/4
C	Floor to Center Line Water Outlet	36	38-3/4	38-3/4	46	46
D	Diameter of Jacket	25-1/4	27	27	27	27
E	Floor to Center Line Water Inlet	12	12	12	12	12
F	Draft Diverter Outlet Diameter	8	10	10	10	12
G	Floor to Center Line Gas Inlet	16-1/2	16-3/4	16-3/4	8	8
H	Overall Depth	29-5/8	31-1/2	31-1/2	36-1/2	36-1/2
J	Support Height	9	9	9	9	9
K	Width of Control String (approx.)	14	14	14	11	11
L	Pipe Size of Water Inlet (NPT)	1-1/4	1-1/2	1-1/2	2	2
M	Pipe Size of Water Outlet (NPT)	1-1/4	1-1/2	1-1/2	2	2
N	Pipe Size of Gas Inlet (NPT)	3/4	3/4	1	1	1
P	Control String Plus 1/2 Jacket Diameter (approx.)	26-5/8	27-1/2	27-1/2	24-1/2	24-1/2
S	Horizontal Length between Water Inlet & Outlet	5-3/8	5-1/2	5-1/2	5-3/4	5-3/4
T	Control String from Jacket	5	5	5	7	7

HOT WATER GENERATOR

STEAM OR BOILER HOT WATER HWG GENERATOR SYSTEMS

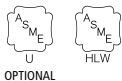

All HWG Systems are Insulated and Jacketed

Integral Circulator Pump

Both Steam and Boiler Water Units are Custom Built to Meet Your Specifications

Optional Steam Trim

- Includes electric operated valve
- Pressure gauge with siphon, vacuum breaker and air vent

Optional Boiler Trim

- Electric high limit safety system
- Pressure gauge with siphon, vacuum breaker and air vent
- Boiler water temperature gauge

ASME Rated

Cathodic Protection

Custom Sizes Available up to 5,000 Gallons

5-Year Limited Tank Warranty and 1-Year Limited Coil Warranty

- For complete warranty information, consult written warranty or go to hotwater.com

Reference specification sheet and submittal, for additional information on coil sizes and recovery rates.

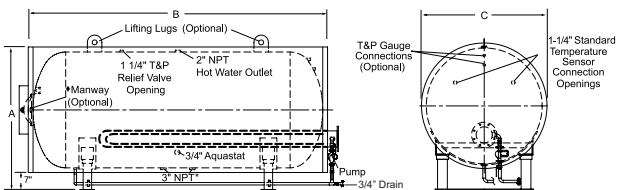
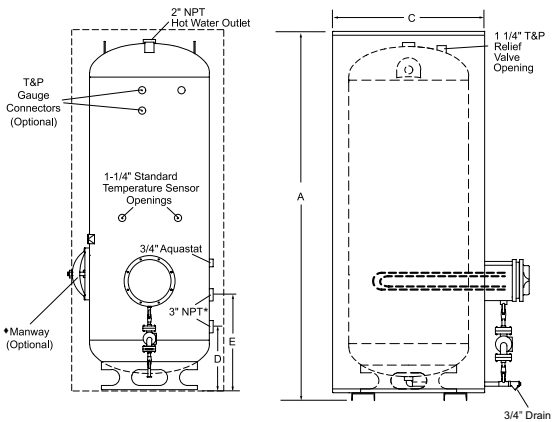

*2" on 120; 2-1/2" on 200 Gal.

Model Number	Height	Length	Width	Gallon
HWGV-120A	63	28	10	120
HWGV-200A	77.25	32	11.25	200
HWGV-250A	91	34	18	257
HWGV-318A	80	40	19.5	318
HWGV-400A	80	46	21	432
HWGV-500A	92	46	21	504
HWGV-650A	92	52	23.5	650
HWGV-750A	104	52	23.5	752
HWGV-1000A	128	52	23.5	940

Model Number	Height	Length	Width	Gallon
HWGH-250A	41	87	34	250
HWGH-300A	47	76	40	300
HWGH-400A	53	76	46	400
HWGH-500A	53	88	46	500
HWGH-600A	59	88	52	600
HWGH-700A	59	100	52	700
HWGH-1000A	59	124	52	1000

COMMERCIAL STORAGE TANKS

STANDARD JACKETED STORAGE TANKS



Glasslined Tank

- Alkaline borosilicate composition permanently fused to steel by firing at a temperature of 1600°F, providing years of corrosion protection and dependable use

Ideal for Use with Gas Fired Copper Heat Exchanger Equipment for Potable Water at Temperatures Up to 180°F

Threaded Openings

- All tanks furnished with threaded openings for thermometer, relief valve, 2" recirculation lines, tank stat, and drain valve

ASME Construction on Select Models.

- 160 psi standard working pressure on all models

Anodic Protection

TJ-80S, TJ-80A, TJV-120M and TJV-120A

- Fits through 30" door
- Magnesium anode for anti-corrosion protection

Meets R12.5 Minimum Thermal Insulation Requirements of the U.S. Department of Energy and Current Edition of ASHRAE/IES 90.1

5-Year Heat Exchanger and 1-Year Parts Limited Warranty

- For complete warranty information, consult written warranty or go to hotwater.com

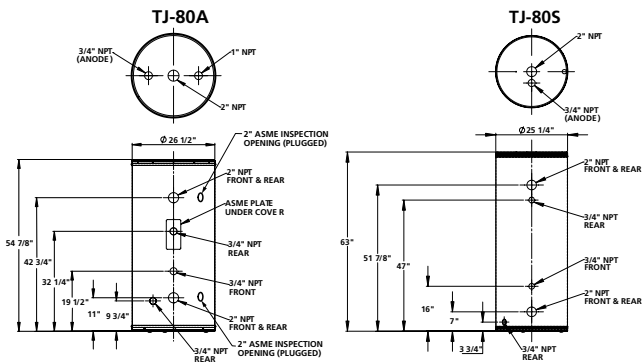

TJV-120A

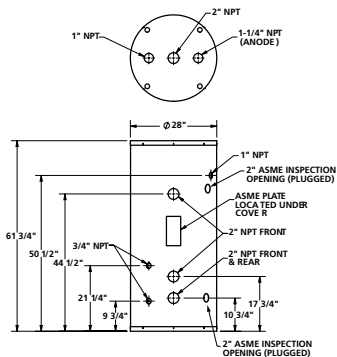

TJV-120M

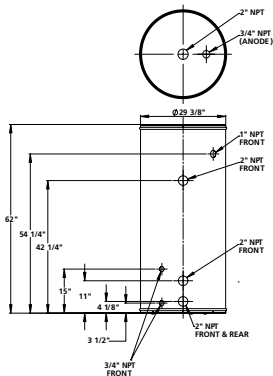

TJV-200M

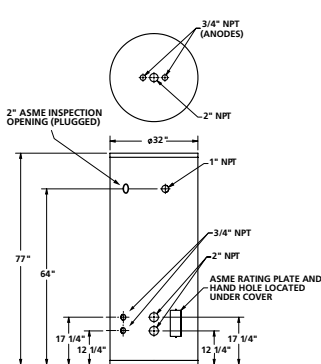

Model Number	Gallon Capacity	Overall Length (Inches)	Diameter (Inches)	Approx. Shipping Weight (lbs)
TJ80S Jacketed-Vertical Only	80	63	25-1/4	236
TJV120M Jacketed-Vertical Only	119	62	29-3/8	320
TJ80A Jacketed-Vertical Only	80	54-7/8	26-1/2	369
TJV-120A	119	61-3/4	28	411
TJV-200M (ASME)	175	77	32	560

COMMERCIAL STORAGE TANKS

STANDARD-LINE FACTORY JACKETED & INSULATED STORAGE TANKS



Standard Sizes

- From 140 to 2,500 gallons
- All stock tanks glasslined

Horizontal or Vertical Mounting

High-Density, Fiberglass Insulated Jackets

Meet R12.5 Minimum Thermal Insulation Requirements of the U.S. Department of Energy and Current Edition of ASHRAE/IES 90.1

ASME Construction

- Available in 125 and 150 working pressures; 125 standard.

Anodic Protection

Accessories

- Tanks will be supplied with the fittings located as indicated on the drawings

Cabinet

- Heavy gauge steel with high quality powder coat paint provides additional insulating qualities for greater energy savings

5-Year Limited Tank Warranty

- For complete warranty information, consult written warranty or go to hotwater.com



Model Number	A	B	C	D	E	F	G	H	"I" ASME Inspection Openings
TJV-140A	87	30	21 1/2	51	8	1-1/2	2-1/2	6-3/8	2"
TJV-200A	83	36	22	45	10	1-1/2	2-1/2	7-3/4	2"
TJV-250A	96	36	22	58	10	1-1/2	2-1/2	7-3/4	2"
TJV-350A	97	42	24 1/2	54	14	1-1/2	2-1/2	9-1/2	2"
TJV-400A	105	42	24 1/2	61	14	1-1/2	2-1/2	9-1/2	2"

VERTICAL ROUND JACKETED ASME

Model Number	A	B	C	D	Gallons
TJVT-500A	91	46	20.875	2"	500
TJV-500A	77	52	22.875	2"	500
TJV-600A	88	52	22.875	2"	600
TJV-700A	97	52	22.875	2"	700
TJV-750A	100	52	22.875	2"	750
TJV-1000A	124	52	22.875	2"	1000

VERTICAL SQUARE JACKETED ASME

Model Number	A	B	C	D	Gallons
TJV-1250A	133	60	24.375	3"	1,250
TJV-1500A	129	66	25.875	3"	1,500
TJV-2000A	126	78	28.375	3"	2,000
TJV-2500A	146.5	78	28.375	3"	2,500

The manhole is standard on all cement and epoxy lined tanks.

HORIZONTAL ROUND JACKETED ASME TANKS

Model Number	A	B	Diameter	Gallons
TJH-250A	41	87	34	250
TJH-300A	47	76	40	300
TJH-400A	53	76	46	400
TJHT-500A	53	87	46	500
TJH-500A	59	77	52	500
TJH-600A	59	88	52	600
TJH-700A	59	97	52	700
TJH-750A	59	100	52	750
TJH-1000A	59	124	52	1000

HORIZONTAL SQUARE JACKETED ASME TANKS

Model Number	A	B	Depth	Gallons
TJH-1250A	68.5	134	60.25	1,250
TJH-1500A	74.5	127	66.25	1,500
TJH-2000A	86.5	127	78.25	2,000
TJH-2500A	86.5	144	78.25	2,500

For Cement or Epoxy linings Order "HD" tanks with jackets and insulation.

COMMERCIAL WATER HEATER STANDARD-LINE FACTORY JACKETED & INSULATED STORAGE TANKS (CONTINUED)

VERTICAL ROUND JACKETED ASME

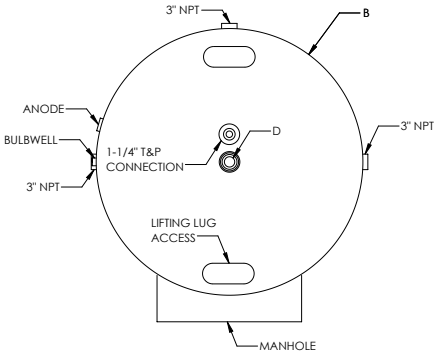
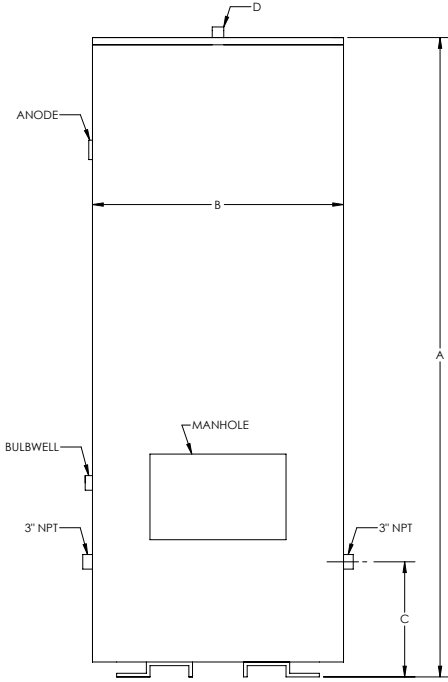

HORIZONTAL ROUND JACKETED ASME

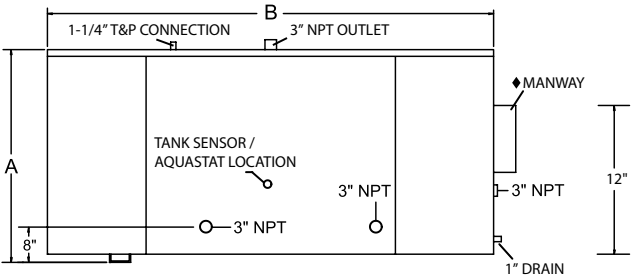
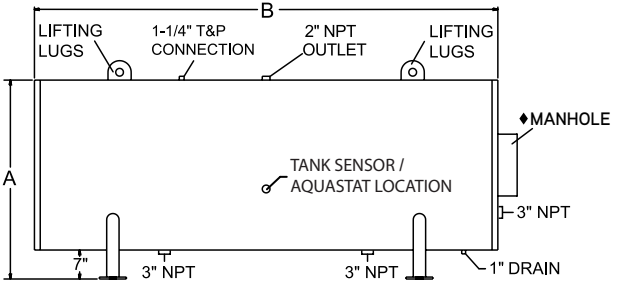

COMMERCIAL STORAGE TANKS

UNINSULATED STANDARD STOCK BARE STORAGE TANKS



Glasslined per ASME, HLW Procedures

Horizontal or Vertical Mounting

High-Density, Bare Steel Tanks

ASME Construction

Magnesium Anodes Protect Against Corrosion.

Meets R12.5 Minimum Thermal Insulation Requirements of the U.S. Department of Energy and Current Edition of ASHRAE/IES 90.1

5-Year Limited Tank Warranty

- For complete warranty information, consult written warranty or go to hotwater.com

Model Number	Gallon Capacity	Overall Dimensions Inches	A	B	C	D	E
T-80 STD	80	20 x 62-1/8	20	61-1/2	2	–	7
T-120 STD	119	24-1/4 x 65	24-1/4	64-3/8	2-1/2	–	7
T-200 STD	200	30 x 72	30	70-3/4	2-1/2	10	13
T-350 STD	350	36 x 88	36	86	2-1/2	14	16
T-140 ASME	140	24 x 76-1/4	24	75	2-1/2	8	12
T-200 ASME	200	30 x 72	30	70-3/4	2-1/2	10	13
T-250 ASME	250	30 x 84	30	84	2-1/2	10	13-1/4
T-350 ASME	350	36 x 88	36	86	2-1/2	14	16
T-400 ASME	400	36 x 97	36	96	2-1/2	14	16

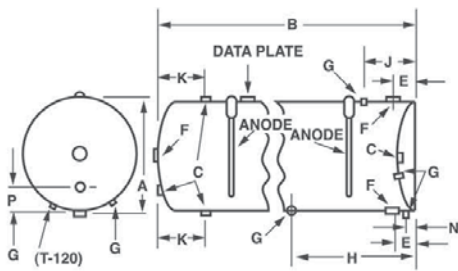

FIGURE 1 - T-80, T-120
NOTE: T-120 SHOWN.

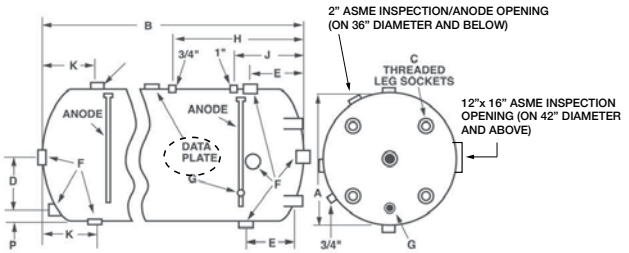

FIGURE 2 - T-140 THRU T-1000A

Model Number	F	G	H	J	K	N	P	Approx. Shipping Weight
T-80 STD	2	3/4	46-1/4	16	3-1/2	3-1/4	4	170
T-120 STD	2-1/2	3/4	34-1/2	15-1/2	10-1/2	3-1/2	4-1/8	287
T-200 STD	2-1/2	3/4	28-1/2	19-1/2	13	-	4	460
T-350 STD	2-1/2	3/4	31-1/2	20-1/4	16	-	4	670
T-140 ASME	2-1/2	3/4	27-1/2	18-1/2	12	-	4	400
T-200 ASME	2-1/2	3/4	28-1/2	19-1/2	13	-	4	460
T-250 ASME	2-1/2	3/4	28-1/2	19-1/2	13	-	4	505
T-350 ASME	2-1/2	3/4	31-1/2	20-1/4	16	-	4	670
T-400 ASME	2-1/2	3/4	31-1/2	20-1/4	16	-	4	775

Working pressure for T models 80 - 400 is 160 PSI

COMMERCIAL WATER HEATER

UNINSULATED STANDARD STOCK

BARE STORAGE TANKS *(CONTINUED)*

Model Number	Gallons	A	B	C	D	Weight (LBS) - Glass 125 psi
TVN-500A	500	42	87	36.875	20.875	763
TV-500A	500	48	77	34.875	18.875	1062
TV-600A	600	48	88	36.875	20.875	1193
TV-700A	700	48	97	36.875	20.875	1301
TV-750A	750	48	100	36.875	20.875	1337
TV-1000A	1000	48	124	36.875	20.875	1623
TV-1250A	1250	54	128	38.375	22.375	2100
TV-1500A	1500	60	124	39.875	23.875	2709
TV-1750A	1750	60	148	39.875	23.875	3156
TV-2000A	2000	72	121	42.375	26.375	3397

Model Number	Gallons	A	B	C	D	E	F	Weight (LBS) - Glass 125 psi
THN-500A	500	42	83	47.5	12	39.5	27.25	763
TH-500A	500	48	73	40.5	12	36.5	28.75	1062
TH-600A	600	48	84	48	12	42	28.5	1193
TH-700A	700	48	93	52.5	12	43.5	30.75	1301
TH-750A	750	48	96	54	12	46	30.75	1337
TH-1000A	1000	48	120	66	12	60	36.5	1623

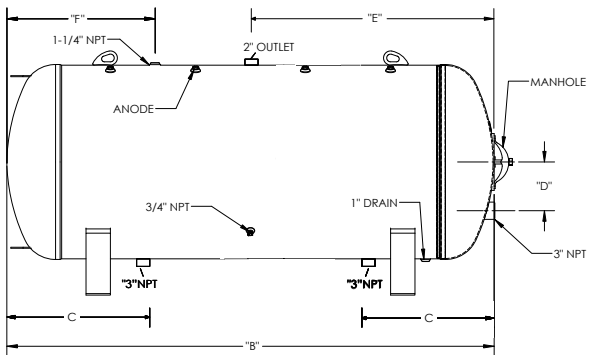
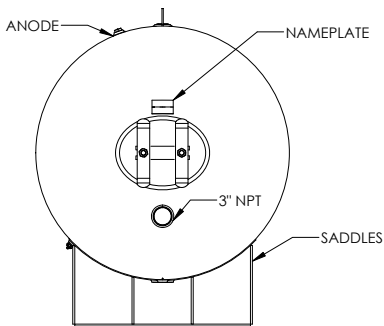
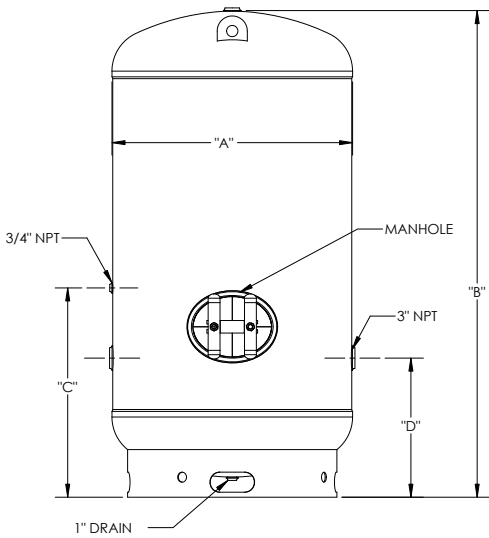

COMMERCIAL STORAGE TANKS

HEAVY-DUTY LARGE VOLUME STORAGE TANKS MODEL HD CUSTOM-BUILT



Custom-Built Tanks From 80 to 4,000 Gallons

Horizontal or Vertical Mounting Options Available

High-Density, Insulated Jackets or Bare Steel Tanks

Glasslined, Cement or Epoxy Linings Available

ASME Construction

- Available in 125, 150 and 160 psi working pressure.

Anodic Protection

Manholes, Handholes, Additional Tank Opening, M Lifting Lugs, Angle Legs, Ring Bases and Horizontal Tanks Saddles All Available as Options

Meets R12.5 Minimum Thermal Insulation Requirements of the U.S. Department of Energy and Current Edition of ASHRAE/IES 90.1

5-Year Limited Tank Warranty

- For complete warranty information, consult written warranty or go to hotwater.com



Model Number	Gallons	Dimensions		
		Diameter	Vertical Height	Horizontal Length
HD*24-120A	118	24"	64"	60"
HD*24-140A	141	24"	76"	72"
HD*24-200A	188	24"	100"	96"
HD*24-250A	235	24"	124"	120"
HD*28-175A	175	28"	65"	-
HD*28-200A	200	28"	76"	-
HD*30-150A	147	30"	52"	48"
HD*30-185A	184	30"	64"	60"
HD*30-220A	220	30"	76"	72"
HD*30-250A	257	30"	87"	83"
HD*30-300A	294	30"	100"	96"
HD*30-375A	367	30"	124"	120"
HD*36-275A	265	36"	64"	60"
HD*36-325A	318	36"	76"	72"
HD*36-400A	370	36"	87"	83"
HD*36-425A	423	36"	100"	96"
HD*36-500A	528	36"	124"	120"
HD*42-450A	432	42"	76"	72"
HD*42-500A	504	42"	88"	84"
HD*42-600A	576	42"	100"	96"
HD*42-750A	720	42"	124"	120"
HD*42-900A	864	42"	148"	144"
HD*42-1000A	1,008	42"	172"	168"
HD*48-700A	658	48"	88"	84"
HD*48-750A	752	48"	100"	96"
HD*48-950A	940	48"	124"	120"
HD*48-1150A	1,128	48"	148"	144"
HD*48-1300A	1,315	48"	172"	168"
HD*48-1500A	1,503	48"	196"	192"
HD*54-1000A	951	54"	100"	96"
HD*54-1200A	1,189	54"	124"	120"
HD*54-1450A	1,427	54"	148"	144"
HD*54-1700A	1,665	54"	172"	168"
HD*54-1900A	1,903	54"	196"	192"
HD*54-2150A	2,141	54"	220"	216"
HD*60-1500A	1,469	60"	124"	120"
HD*60-1750A	1,763	60"	148"	144"
HD*60-2000A	2,056	60"	172"	168"
HD*60-2400A	2,350	60"	196"	192"
HD*60-2650A	2,644	60"	220"	216"
HD*72-2100A	2,115	72"	124"	120"
HD*72-2500A	2,538	72"	148"	144"
HD*72-3000A	2,961	72"	172"	168"
HD*72-3400A	3,384	72"	196"	192"
HD*72-4000A	3,807	72"	220"	216"

Specify Horizontal or Vertical installation H or V (after the HD)

For Jacketed models , the J will follow the orientation: HDVJ48-1500A.

For foam insulation, O represents Outdoor: HDVO48-1500A

For linings other than glass, use the suffix after the number and the A - HDHJ42-1000AE for and Epoxy lined or HDHJ42-100AC for Cement lined. U = Unlined.

For 150 PSI ASME working pressure, insert M at the end - HDV42-1000AM

COMMERCIAL STORAGE TANKS

HEAVY-DUTY LARGE VOLUME STORAGE TANKS MODEL HD

CUSTOM-BUILT *(CONTINUED)*

FACTORY INSULATION OPTIONS

Factory Jacketed and Insulation

- **INSULATION** — Entire tank is surrounded with insulation
- **CABINET** — Heavy gauge painted steel
- Adds 4" to the round jacketed and 6" to the square jacketed diameter of the tank

OUTDOOR FOAM INSULATION

- **INSULATION** — Entire tank is sprayed with minimum of 2" high-density polyurethane foam insulation that forms a watertight jacket that is approved for outdoor use
- Adds 6" to the diameter of the tank, and 2" to the height

Note: Minimum foam insulation thickness is 2"; however, since tank is hand sprayed, insulation thicknesses may be greater in some areas giving the finished tank an uneven but watertight surface.

Tank Diameter
30 36 42 48 54 60 72

A 21" 25" 29" 34" 48" 52" 62"

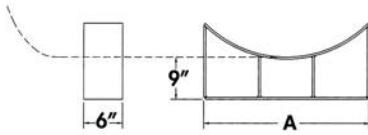

NOTE: Alternate saddle heights are available.
(Consult factory)

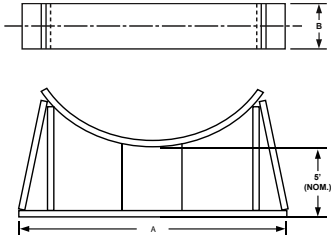

TANK SADDLES

A.O. SMITH PART NO.	SADDLE DESCRIPTIONS
100170345	SADDLE, TANK, 24", 9" CLR, P-1
100170349	SADDLE, TANK, 30", 9" CLR, P-1
100170338	SADDLE, TANK, 28", 9" CLR, P-1
100170352	SADDLE, TANK, 36", 9" CLR, P-1
100170355	SADDLE, TANK, 42", 9" CLR, P-1
100170358	SADDLE, TANK, 48", 9" CLR, P-1
100170361	SADDLE, TANK, 54", 9" CLR, P-1
100170365	SADDLE, TANK, 60", 9" CLR, P-1
100170371	SADDLE, TANK, 72", 9" CLR, P-1

COMMERCIAL WATER HEATER

AC-U-TEMP COMPLETE HOT WATER SYSTEMS



Standard Tank Sizes from 80 to 1000 Gallons

Ac-U-Temp System Eliminates Costly Field Errors

Simplifies Installation

Standard Ac-U-Tanks are Factory Jacketed and Insulated

All Systems are Built to Order

Multi-Heater Systems for 50%-100% Back-Up

Superior Channel Iron

Factory Hydrostatic and Fire-Tested Before Shipping

ASME Relief Valve 125#

Tank Temperature Sensor

Tank Thermometer

Isolation Valves

Custom Tank Sizes to 5,000 Gallons

5-Year Limited Heat Exchanger Warranty and 5-Year Limited Tank Warranty

- For complete warranty information, consult written warranty or go to hotwater.com



CONSULT THE XPERT.



Confidently select the right water heater for your floor plans with the help of an Xpert. With just a few quick questions, the Xpert Product Selection Tool evaluates A. O. Smith's full range of product options against your installation, energy efficiency and usage requirements. The result is a custom selection of water heaters recommended just for you.

Visit hotwater.com/Xpert
to consult the Xpert
or download the A. O. Smith App.





A. O. Smith | 500 Tennessee Waltz Parkway | Ashland City, TN 37015
800.527.1953 | hotwater.com

AOSAA80000 | © April 2020 | A. O. Smith Corporation | Printed in U.S.A.